

Topic 01: Case Studies in Embedded Sensor Applications

Tuesday 20 Feb 2007

ICTP-ITU School on Wireless Networking for Scientific Applications in Developing Countries

Bhaskaran Raman
Department of CSE, IIT Kanpur

<http://www.cse.iitk.ac.in/users/braman/>

Outline

- Embedded wireless sensor networks: what? why?
 - Overview of potential applications
- Case studies (* indicates amount of detail):
 - Great Duck Island habitat monitoring (****)
 - Redwood tree micro-climate monitoring (**)
 - Volcano monitoring (**)
 - Bridge monitoring (**)
 - Industrial motor monitoring (*)

Outline

- Embedded wireless sensor networks: what? why?
 - Overview of potential applications
- Case studies (* indicates amount of detail):
 - Great Duck Island habitat monitoring (****)
 - Redwood tree micro-climate monitoring (**)
 - Volcano monitoring (**)
 - Bridge monitoring (**)
 - Industrial motor monitoring (*)

Wireless Sensor Networks

- What are sensors?
- Why “wireless” sensor “networks”?
- What do we need to make a wireless sensor network node?
 - Sensor
 - Processing
 - Memory
 - Radio
 - Called a **sensor mote**

Sensor Motes

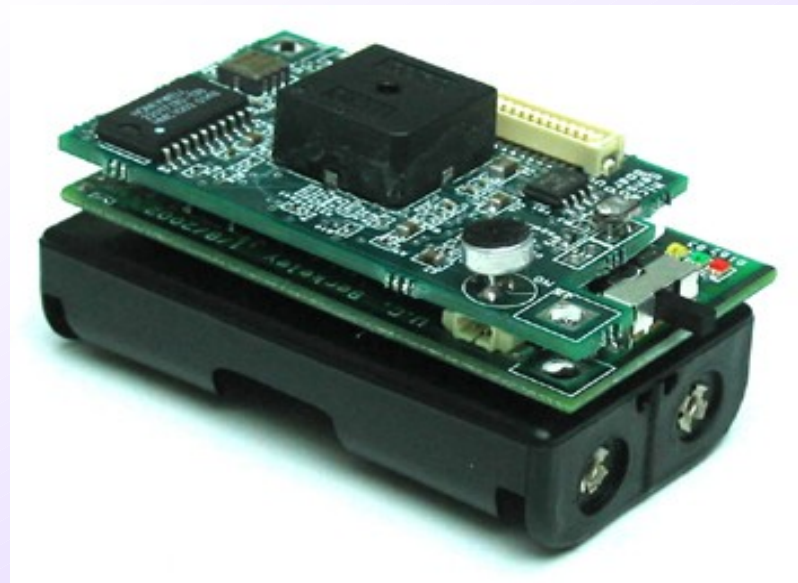
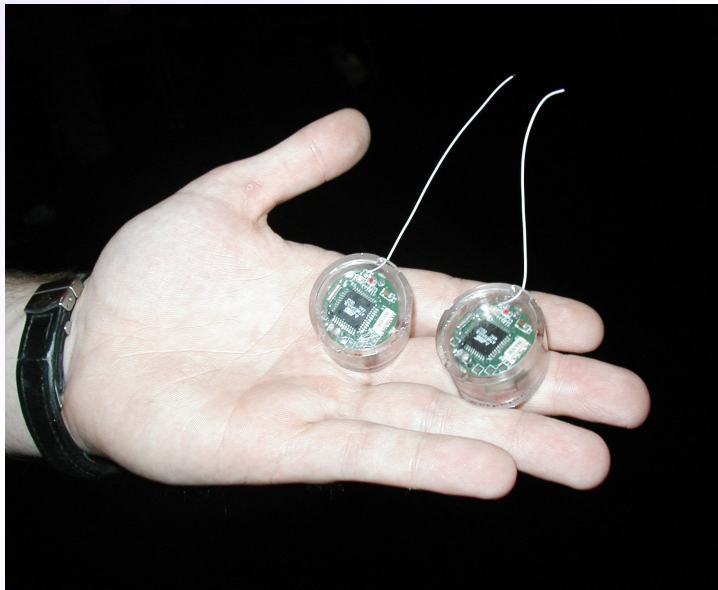
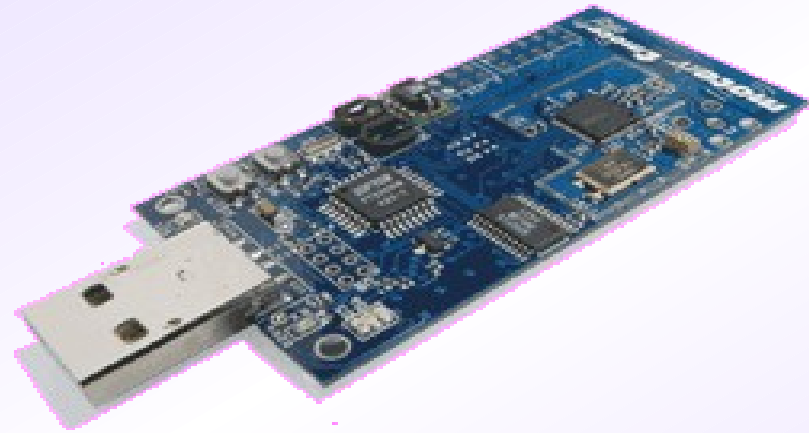

Pictures courtesy Google

Embedded Wireless Sensor Networks

- Trends in semi-conductor technology
 - Moore's Law
 - More silicon per unit area
 - More processing per unit area
 - Miniaturization becomes possible
- Miniaturization of: computing, radios, sensors
- **Reference:** “Overview of Sensor Networks”, D. Culler, D. Estrin, M. Srivastava, IEEE Computer Aug 2004

Sensor Network Applications

- Monitoring space
- Monitoring things
- Monitoring interaction of things in an encompassing space

Applications: Monitoring Spaces

- Environmental and habitat monitoring, precision agriculture, indoor climate control

Biological: Habitat



Chemical: Rivers



Physical: Agriculture



Pictures courtesy Google

Monitoring Things

- Structural monitoring, condition based equipment maintenance, patient health monitoring/diagnostics

Bridge Health



Equipment Maintenance



Medical Diagnostics



Pictures courtesy Google

Monitoring Interaction of things in an encompassing space

- Wildlife tracking, disaster management, manufacturing process flow

Animal Tracking



Disaster Management



Pictures courtesy Google

Taboo Application Space

- Non-technical, political point (any technology space which requires funding cannot be purely technical)
- For these lectures, we will talk about **no military applications**
- Why is this taboo?
 - What is the most technologically advanced military doing today?
 - My opinion: such applications will only add to human suffering

Processing, Storage, Battery

- **Microprocessors:**
 - 1 mW at about 10MHz speed
 - Duty cycle of 1% \implies 10 micro-watts
- **Memory:**
 - About 10KB of RAM, 100KB of ROM
- **Battery:**
 - Typically about 1AH per cu.cm.
 - Solar power: 10mW per sq.cm. outdoors, 0.01-0.1mW per sq.cm. indoors
 - Mechanical vibrations: 0.1 mW

Sensors, Radios

- **Sensors:**
 - Size, power consumption depends on kind of sensor
 - Typically a few mW
 - Can be quite high too
- **Radios:**
 - About 10-20mW for upto 10m range
 - Multi-hop network
 - Tx of 1 bit == about 1000 instructions

Sensor Mote Requirements

- Typically long running, even up to one year
- Some basic processing and networking
- No electricity
- Interaction with environment rather than user

Issues in Sensor Networks

- MAC, routing, data dissemination
 - Energy conservation
 - Lots of literature in this domain
- Localization, time synchronization
- Topology, power control
- Operating system or software support
- Need to look at case studies to appreciate these...

Outline

- Embedded wireless sensor networks: what? why?
 - Overview of potential applications
- Case studies (* indicates amount of detail):
 - Great Duck Island habitat monitoring (****)
 - Redwood tree micro-climate monitoring (**)
 - Volcano monitoring (**)
 - Bridge monitoring (**)
 - Industrial motor monitoring (*)

A Detailed Study of a Sensor Network Application

- **Reference:** “Wireless Sensor Networks for Habitat Monitoring”, A. Mainwaring, J. Polastre, R. Szewczyk, D. Culler, J. Anderson, WSNA (Wireless Sensor Networks and Applications), Sep 2002
- Monitoring seabird nesting environment (Leach’s Storm Petrel)



Picture: Courtesy Google

Great Duck Island, Maine

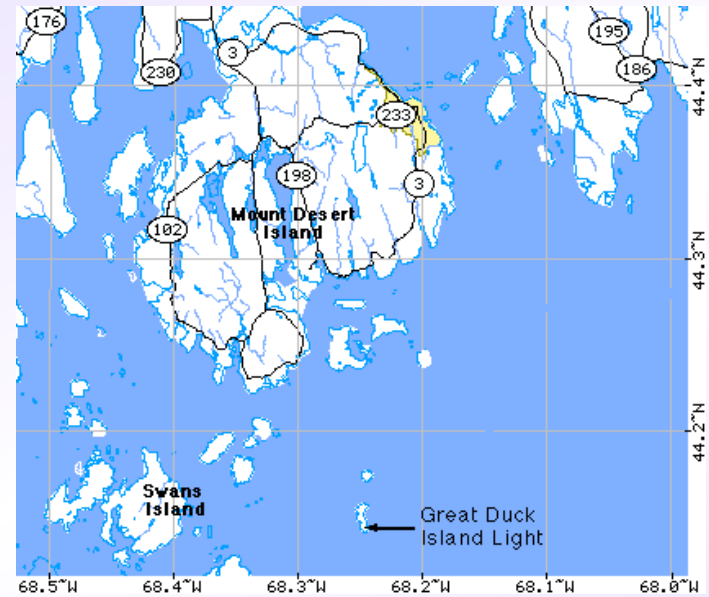

Pictures:
Courtesy
Google



© Jeremy D'Entremont
all rights reserved

Habitat Monitoring and Sensor Networks

- Impacts of human presence on plants and animals
- Minimal disturbance is crucial while monitoring
 - Especially seabird colonies
 - 20% mortality of eggs due to a 15-min visit
 - Repeated disturbance ==> birds may abandon
 - Leach's storm petrels desert nesting burrows if disturbed in first 2 weeks of incubation
- Natural answer: wireless sensor networks

Motivation: Life Scientists' Perspective

- Usage pattern of nesting burrows over the 24-72 hour cycle when one or both members of a breeding pair alternate incubation and feeding at sea
- Changes in burrow and surface environmental parameters during the 7-month breeding season
- Differences in micro-environments with and without large numbers of nesting petrels

Motivation: Sensor Networks Perspective

- Application-driven approach better than abstract problem statements
 - Separate actual problems from potential ones
 - Relevant versus irrelevant issues
- Develop an effective sensor network architecture
 - Learn general solutions from specific ones

Data Acquisition Rates

- Presence/absence data: using temperature differentials
 - Every 5-10 min
- General environmental parameters:
 - Every 2-4 hours
- Popular vs unpopular sites:
 - Every 1 hour, at the beginning of the breeding season

System Goals

- Sensor network longevity: 9 months
 - Solar power where possible
 - Stable operation crucial
- Inconspicuous deployment
- Sensors: light, temperature, infrared, relative humidity, barometric pressure
- Remote data acquisition, management, and monitoring over the Internet
 - Interactive “drill-down”
 - In-situ operations also

System Architecture

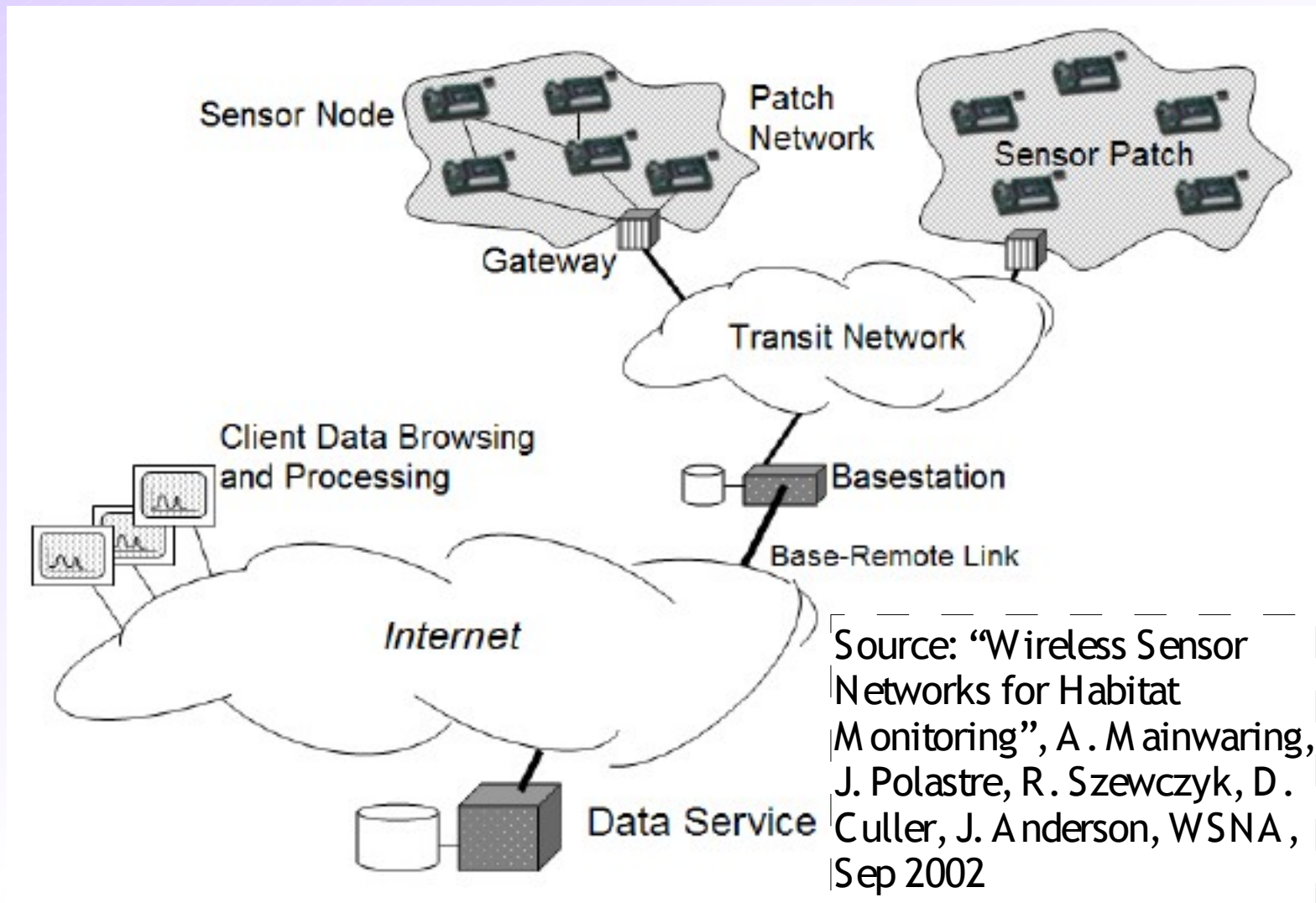
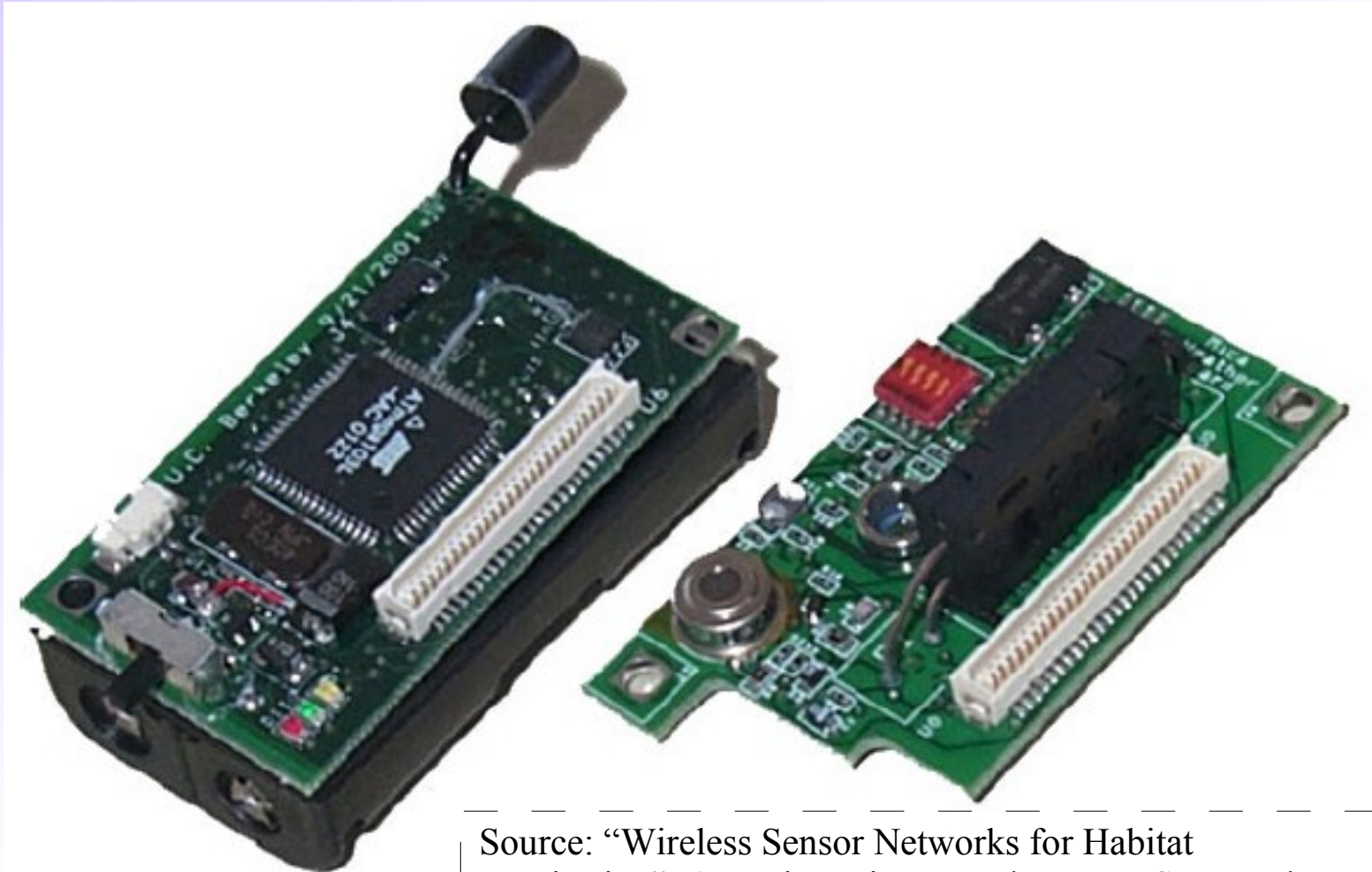

Figure 1: System architecture for habitat monitoring

Remarks on the Architecture

- Hierarchical network
- Solar panel at gateways and base-station
- In-situ **retasking** possible
 - Example: collect temperature beyond a certain threshold, no need for all temperature readings
- Base-station has satellite connectivity
- Base-station has RDBMS, backed up every 15-min to server at UC Berkeley

The Hardware Platform



Source: “Wireless Sensor Networks for Habitat Monitoring”, A. Mainwaring, J. Polastre, R. Szewczyk, D. Culler, J. Anderson, WSN, Sep 2002

Figure 2: Mica Hardware Platform: The Mica sensor node (left) with the Mica Weather Board developed for environmental monitoring applications

Features of the Platform

- Mote called **Mica**:
 - 4MHz Atmel Atmega 103 microcontroller
 - Single channel 916 MHz radio from RF Monolithics (40Kbps)
- **Battery**: pair of AA + DC boost converter
- **Size**: 2.0 x 1.5 x 0.5 inches
- Separate **sensor board** called the Mica weather board

Packaging and Deployment



Source: “Wireless Sensor Networks for Habitat Monitoring”, A. Mainwaring, J. Polastre, R. Szewczyk, D. Culler, J. Anderson, WSNA, Sep 2002

Figure 3: Acrylic enclosure used for deploying the Mica mote.

Sensor Characteristics

Sensor	Accuracy	Interchangeability	Sample Rate	Startup	Current
Photoresistor	N/A	10%	2000 Hz	10 ms	1.235 mA
I ² C Temperature	1 K	0.20 K	2 Hz	500 ms	0.150 mA
Barometric Pressure	1.5 mbar	0.5%	10 Hz	500 ms	0.010 mA
Barometric Pressure Temp	0.8 K	0.24 K	10 Hz	500 ms	0.010 mA
Humidity	2%	3%	500 Hz	500-30000 ms	0.775 mA
Thermopile	3 K	5%	2000 Hz	200 ms	0.170 mA
Thermistor	5 K	10%	2000 Hz	10 ms	0.126 mA

Table 1: Mica Weather Board: Characteristics of each sensor included on the Mica Weather Board.

Source: “Wireless Sensor Networks for Habitat Monitoring”, A. Mainwaring, J. Polastre, R. Szewczyk, D. Culler, J. Anderson, WSNA, Sep 2002

Energy Budget

Total energy available: 2200 mAh
== 8.148 mAh/day x 9 months

Operation	nAh
Transmitting a packet	20.000
Receiving a packet	8.000
Radio listening for 1 millisecond	1.250
Operating sensor for 1 sample (analog)	1.080
Operating sensor for 1 sample (digital)	0.347
Reading a sample from the ADC	0.011
Flash Read Data	1.111
Flash Write/Erase Data	83.333

Source: “Wireless Sensor Networks for Habitat Monitoring”, A. Mainwaring, J. Polastre, R. Szewczyk, D. Culler, J. Anderson, WSNA, Sep 2002

Table 2: Power required by various Mica operations.

Gateway: Design Choices

- 802.11b based
 - CerfCube platform: StrongArm-based
 - IBM micro-drive with 1GB storage
 - 2.5W power consumption
 - 12dBi omni-antenna \implies 1000 feet range
- Mote-mote connection
 - 14dBi directional antenna \implies 1200 feet range
- Packet reception rate was similar in either case, but former requires solar panel

Great Duck Island Burrow 95: Thermopile Data

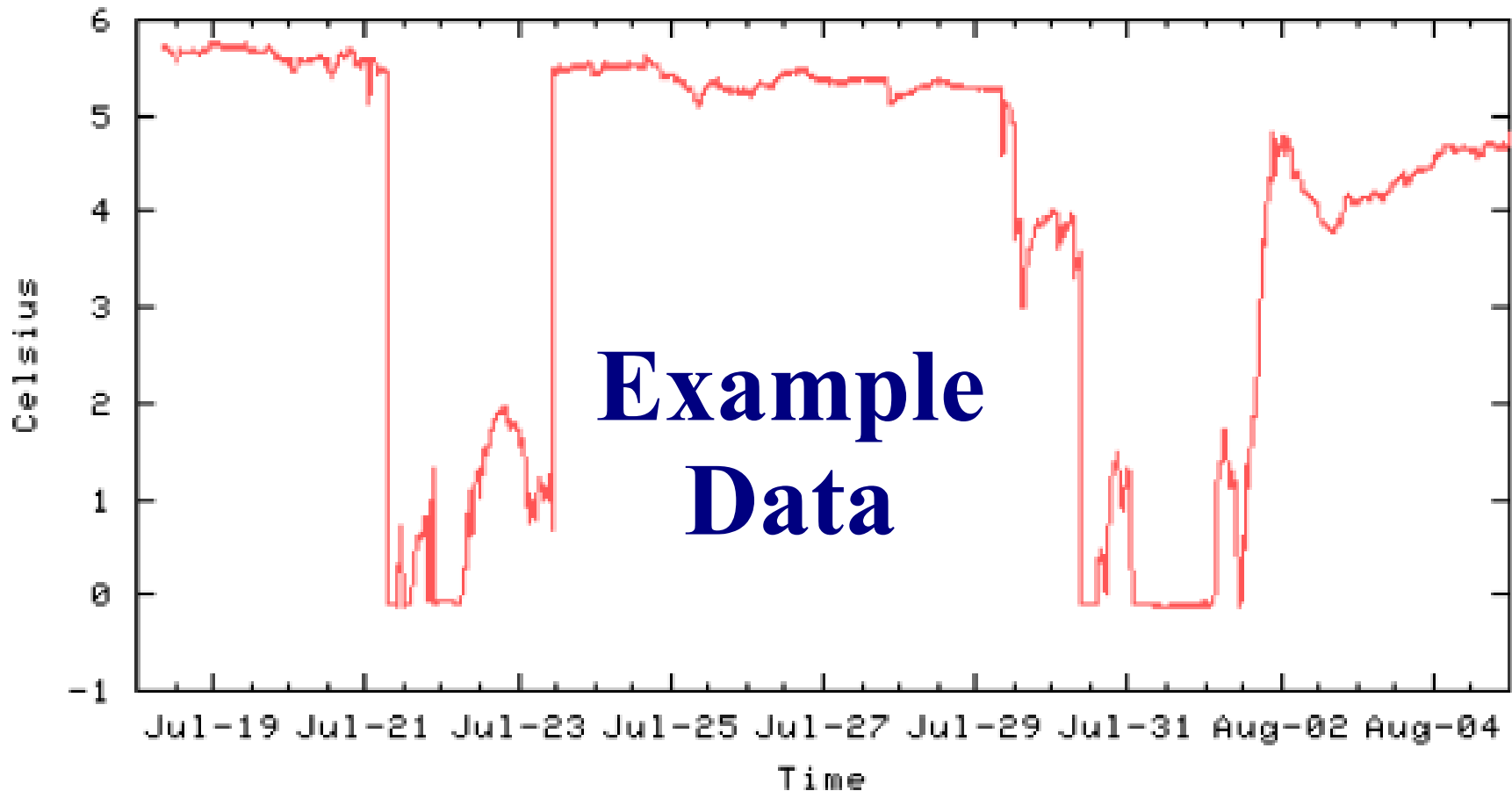

Source: “Wireless Sensor Networks for Habitat Monitoring”, A. Mainwaring, J. Polastre, R. Szewczyk, D. Culler, J. Anderson, WSNA, Sep 2002

Figure 4: Thermopile data from a burrow mote on GDI during a 19-day period (July 18, 2002 to August 5, 2002).

Temperature difference due to bird (verified using recorded bird call)

Communication Protocols

- MAC protocol, routing protocol
- Current implementation: single-hop communication to gateway
 - Periodically scheduled
- Possibilities:
 - Determine routing tree, wake up adjacent levels periodically
 - Wake up nodes along a path or subtree periodically
- Low power MAC: extend start symbol to match the wake-up frequency

Outline

- Embedded wireless sensor networks: what? why?
 - Overview of potential applications
- Case studies (* indicates amount of detail):
 - Great Duck Island habitat monitoring (****)
 - Redwood tree micro-climate monitoring (**)
 - Volcano monitoring (**)
 - Bridge monitoring (**)
 - Industrial motor monitoring (*)

Environment Monitoring: Example

- Redwood trees: microclimate monitoring
 - Rate of photosynthesis
 - Water and nutrient transport
 - Growth patterns
- Prior approach: suite of instruments, wires
- Can use wireless sensors instead

Source: Overview of Sensor Networks, D. Culler, D. Estrin, M. Srivastava, IEEE Computer Aug 2004

The Sensor Node

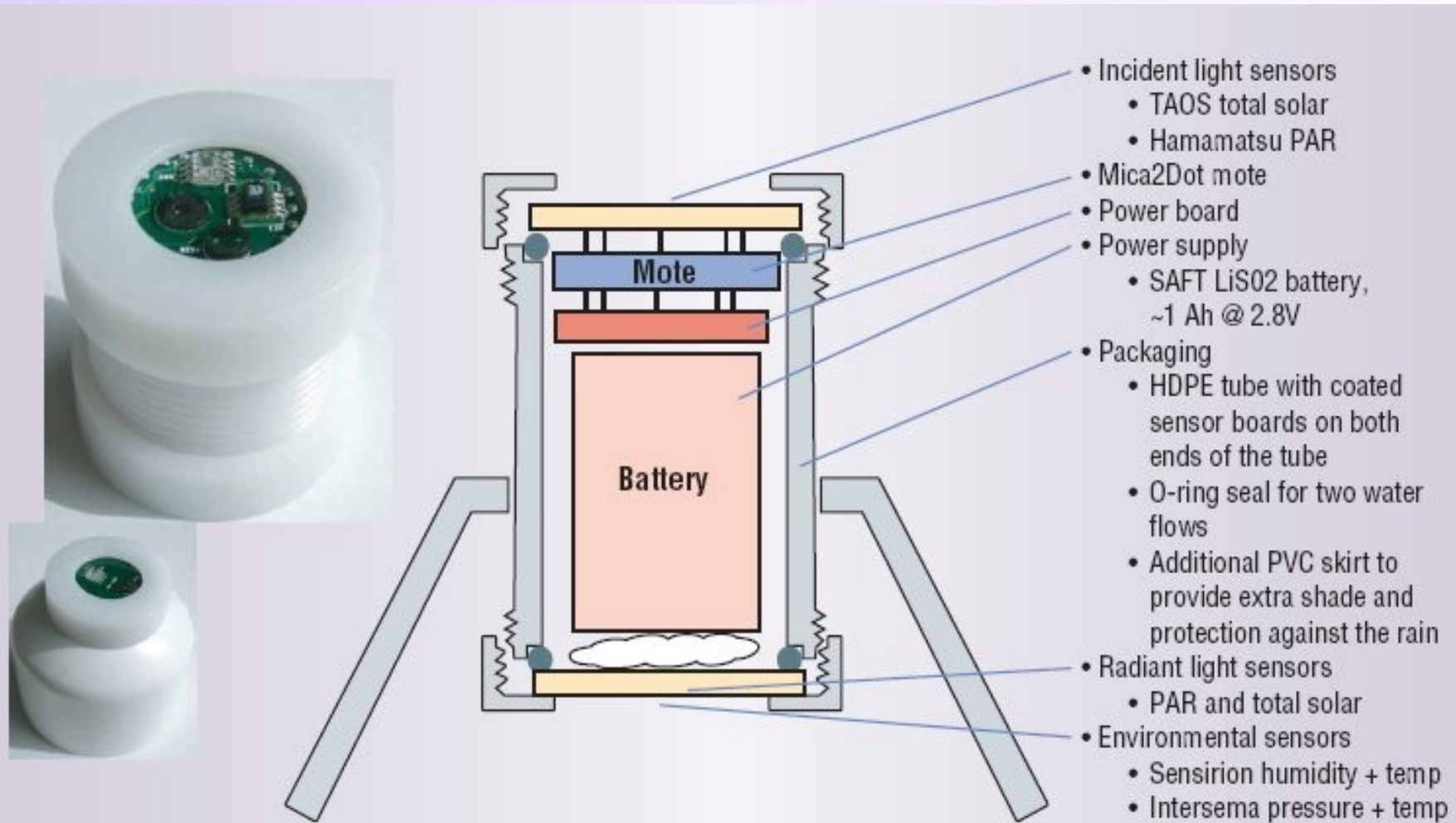

Source: Overview of Sensor Networks, D. Culler, D. Estrin, M. Srivastava, IEEE Computer Aug 2004

Some Measurements

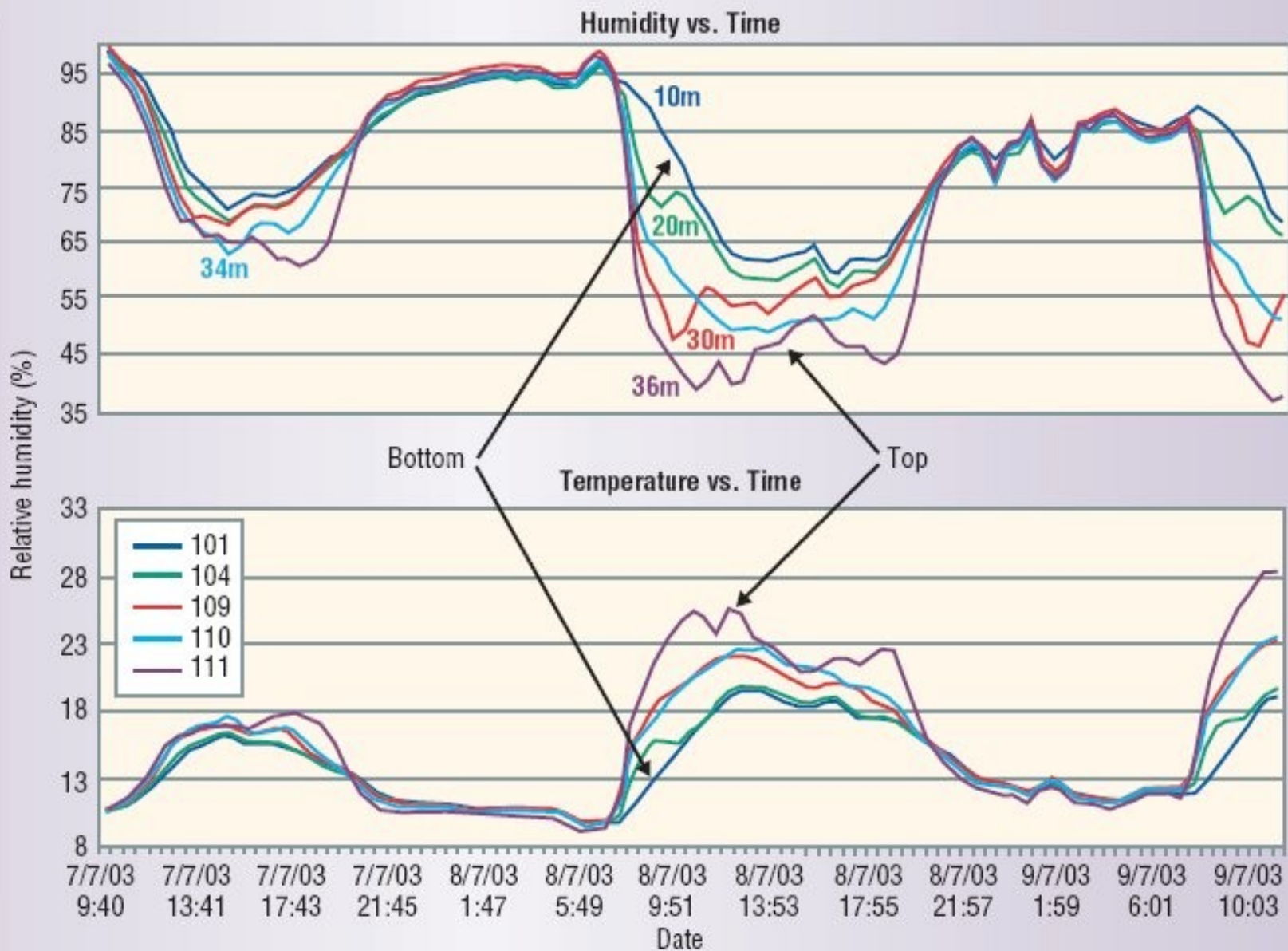

Source: Overview of Sensor Networks, D. Culler, D. Estrin, M. Srivastava, IEEE Computer Aug 2004

Wireless Sensor Network for Volcano Monitoring

- **Reference:** “Deploying a Wireless Sensor Network on an Active Volcano”, Geoffrey Werner-Allen, Konrad Lorincz, Matt Welsh, Omar Marcillo, Jeff Johnson, Mario Ruiz, Jonathan Lees, IEEE Internet Computing, Mar/Apr 2006



Source: “Deploying a Wireless Sensor Network on an Active Volcano”, G. Werner-Allen et. al., IEEE Internet Computing, Mar/Apr 2006

Tungurahua, Ecuador



Source: “Deploying a Wireless Sensor Network on an Active Volcano”,
Presentation by Matt Welsh, Harvard University

Monitoring Equipment

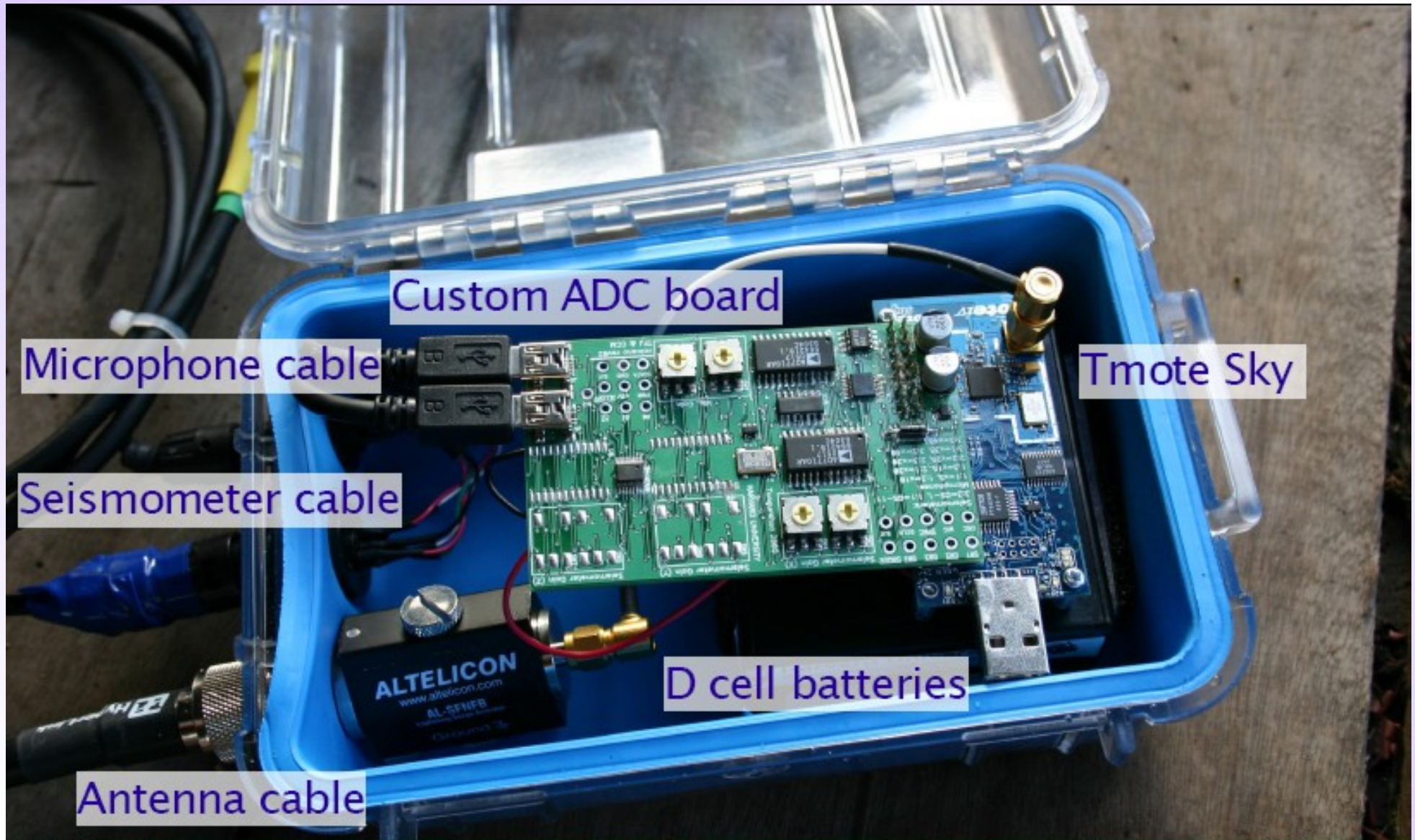

Source: “Deploying a Wireless Sensor Network on an Active Volcano”,
Presentation by Matt Welsh, Harvard University

Sensor Network Architecture

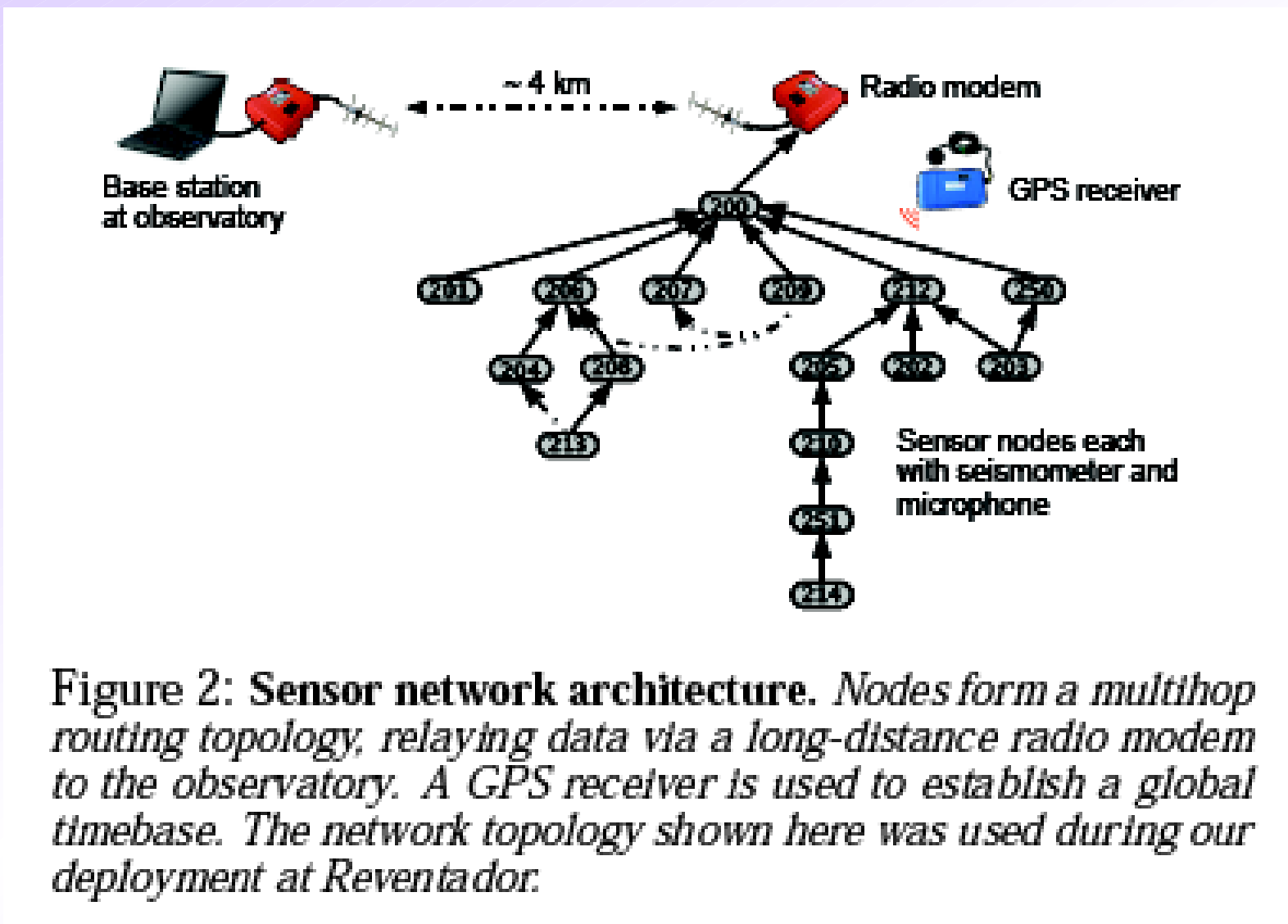
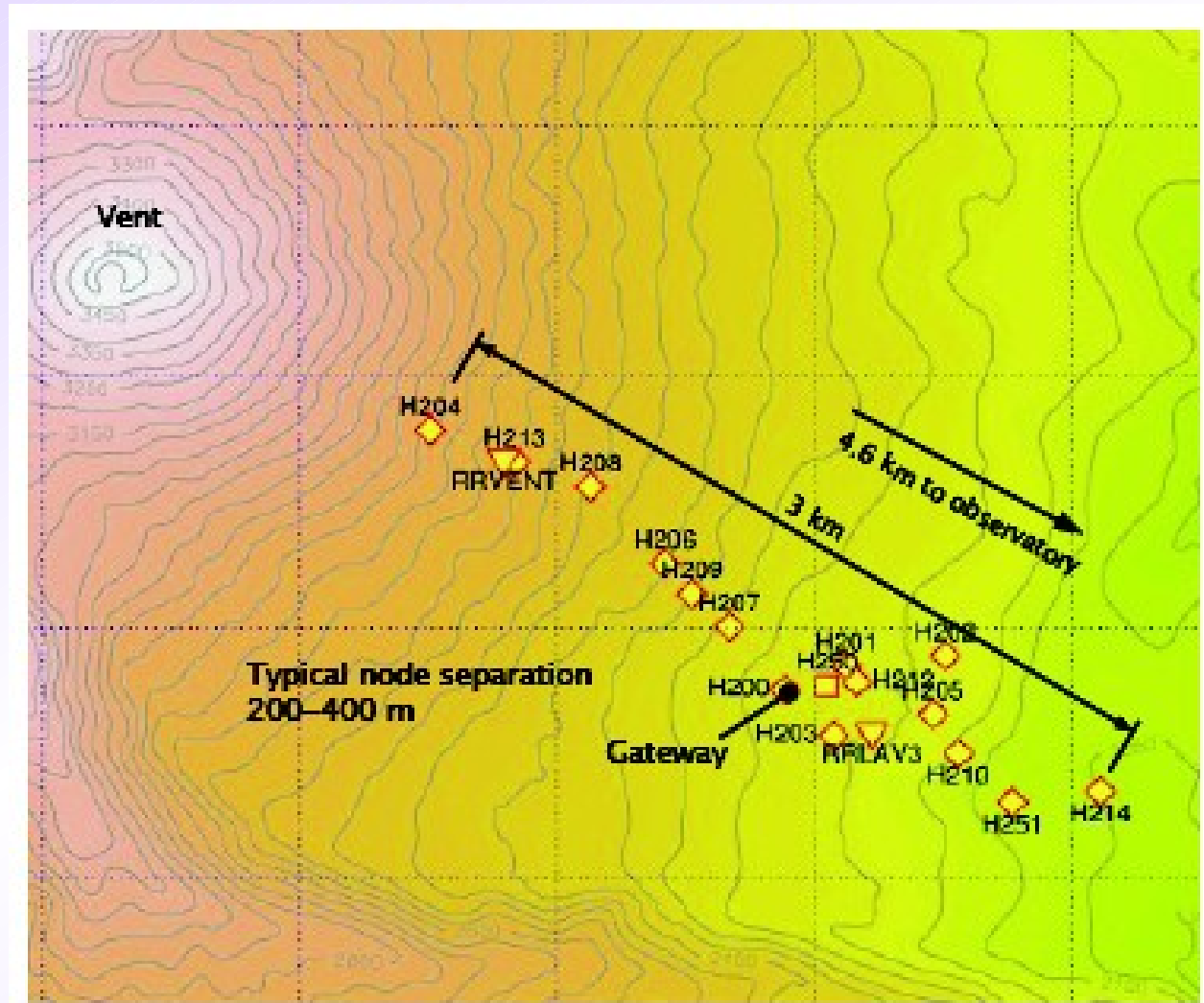

Figure 2: **Sensor network architecture.** *Nodes form a multihop routing topology, relaying data via a long-distance radio modem to the observatory. A GPS receiver is used to establish a global timebase. The network topology shown here was used during our deployment at Reventador.*

Source: "Fidelity and Yield in a Volcano Monitoring Sensor Network", G. Werner-Allen et. al., OSDI 2006

Deployment Map



Source: “Fidelity and Yield in a Volcano Monitoring Sensor Network”, G. Werner-Allen et. al., OSDI 2006

Figure 3: Map of sensor deployment at Volcán Reventador. *In addition to the 16 sensor nodes, two broadband seismometers with data loggers (RRVENT and RRLAV3) were colocated with the network.*

Challenges Encountered

- **Event detection**: when to start collecting data?
- High data rate **sampling**
- Spatial **separation** between nodes
- **Data transfer** performance: reliable transfer required
- **Time synchronization**: data has to be time-aligned for analysis by seismologists

BriMon: Wireless Sensor Network based Bridge Monitoring

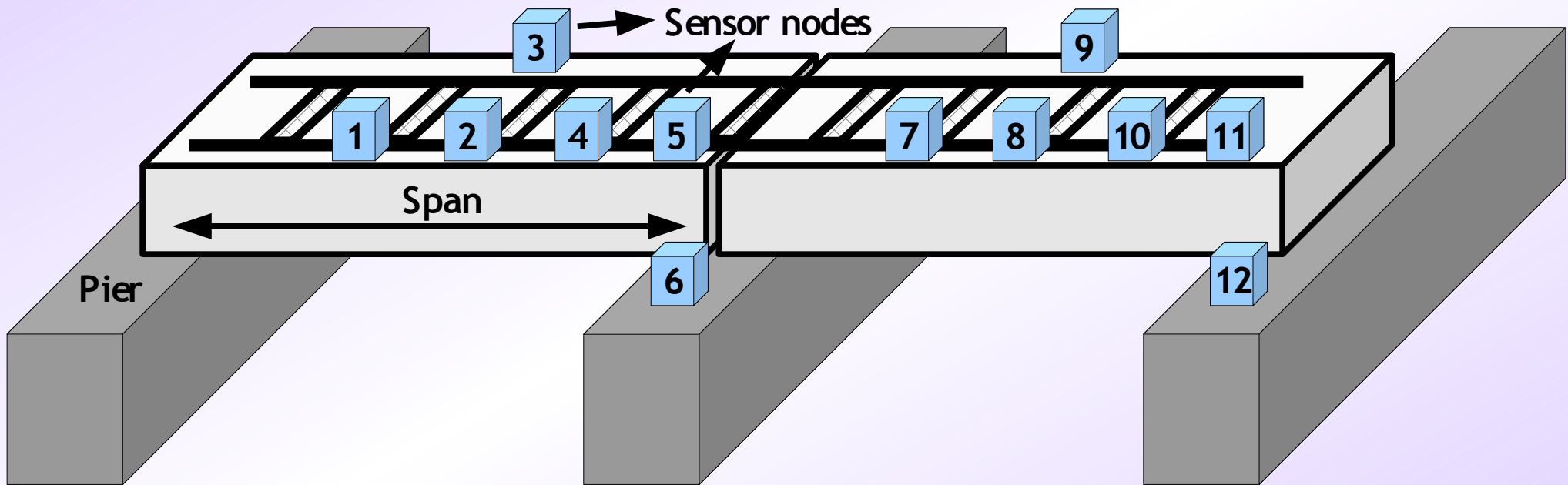

Two main issues: (1) Event detection, (2) Data transfer

Project at IIT-Kanpur: <http://www.cse.iitk.ac.in/users/braman/brimon.html>

BriMon Field Trip (1/2)

Motes connected to
8dBi omni antennas



BriMon Field Trip (2/2)

Base mote,
connected to a
laptop via USB
cable



More Applications: Industrial Monitoring

Source: “WiBeaM:Wireless
Bearing Monitoring System”,
Lt Cdr VMD Jagannath,
Bhaskaran Raman, WISARD
2007.



Fig. 7. Motor with sensor mounted

Challenge

- Lots of sensor network literature claims: applications involving 100s or 1000s of nodes
- Think of one such application
 - Must be as well grounded as possible (preferably an extension of something which has already been built)
 - Specify what is being sensed, how often, etc.
 - Ensure that a sensor “network” is needed
 - Preferably non-military

Summary

- Embedded Wireless Sensor Networks:
 - Possible today due to advances in several domains
 - Some interesting applications have been built