

Link Budget Calculation

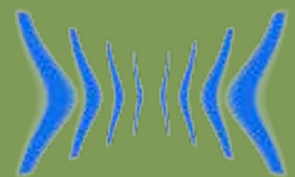

RadioCommunications
Unit of the **ICTP ARPL**

Marco Zennaro
mzennaro@ictp.it
Carlo Fonda
cfonda@ictp.it

Link Planning

- ▶ How long can a wireless link be?
- ▶ How much power can we use?
- ▶ What kind of antennas should be use?
- ▶ Do the connection cables effect the link?
- ▶ What is the effect of trees?

dB math

- ▶ **decibels** are a **relative** measurement unit unlike the absolute measurement of milliwatts
- ▶ on the logarithmic scale, the reference cannot be zero because the log of zero does not exist!
- ▶ $\log(0)$ is undefined!

dB math

- ▶ the reference point that relates the logarithmic dB scale to the linear watt scale is:
 - ▶ **1 mW = 0 dBm**
- ▶ the m in dBm refers to the fact that the reference is 1 mW and therefore a dBm measurement is a measurement of absolute power

dB math

- ▶ to convert mW to dBm:
 - ▶ $P(\text{dBm}) = 10 \log P(\text{mW})$
- ▶ to convert dBm to mW:
 - ▶ $P(\text{mW}) = \log^{-1} (P(\text{dBm})/10)$
- ▶ the advantage of using dB is that **gains and losses are ADDITIVE**

dB math

- ▶ gain or loss in an RF system may be referred to by absolute power measurement (10W of power) or by a relative power measurement (half of its power)
- ▶ -3dB = half the power in mW
- ▶ **+3dB = double the power in mW**
- ▶ -10dB = one tenth the power in mW
- ▶ **+10dB = ten times the power in mW**

dB math

▶ for example:

▶ $10 \text{ mW} + 3 \text{ dB} = 20 \text{ mW}$

▶ $100 \text{ mW} - 3 \text{ dB} = 50 \text{ mW}$

▶ $10 \text{ mW} + 10 \text{ dB} = 100 \text{ mW}$

▶ $300 \text{ mW} - 10 \text{ dB} = 30 \text{ mW}$

dB math

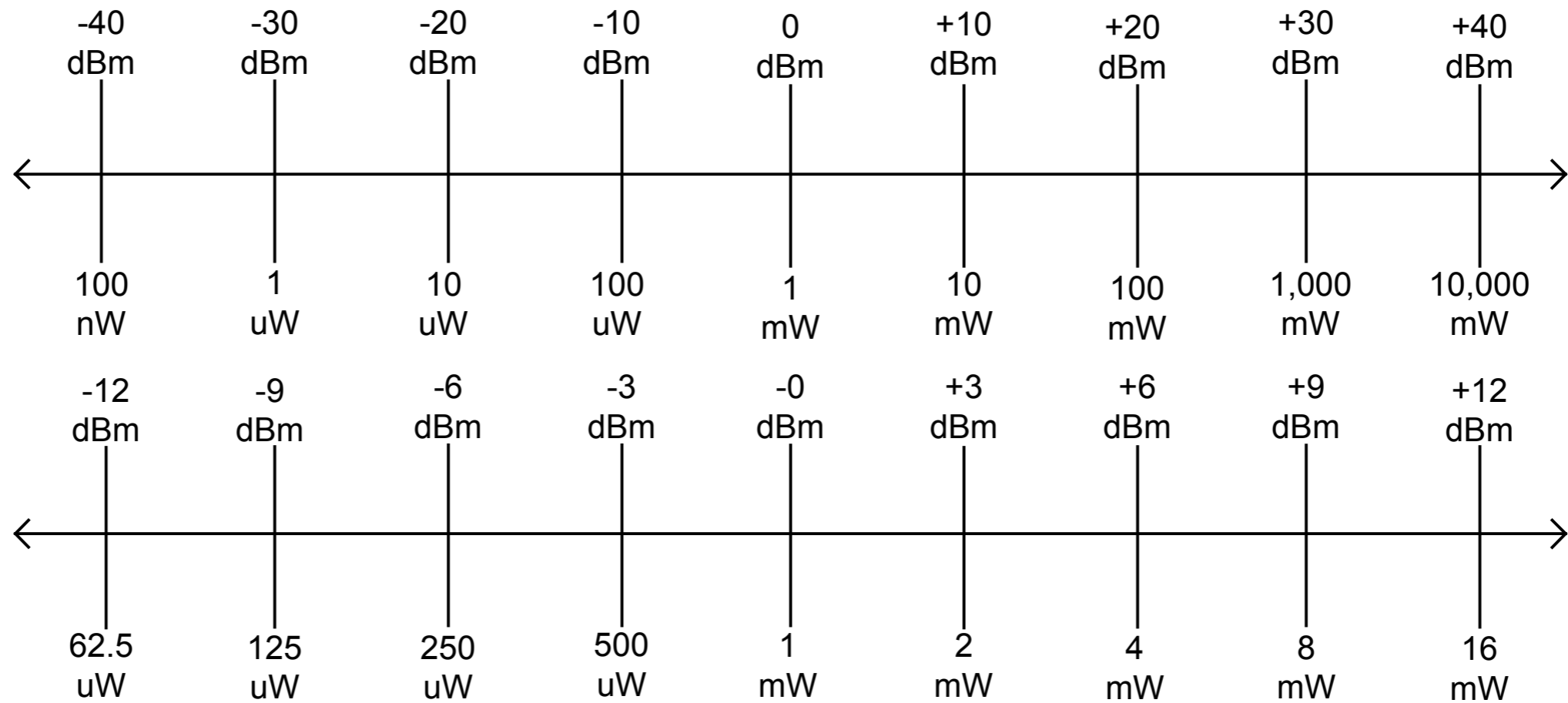

dB math

- ▶ for example:
 - ▶ +43 dBm
 - ▶ $43\text{dB} = 10\text{dB} + 10\text{dB} + 10\text{dB} + 10\text{dB} + 3\text{dB}$
 - ▶ $1\text{ mW} \times 10 = 10\text{ mW}$
 - ▶ $10\text{ mW} \times 10 = 100\text{ mW}$
 - ▶ $100\text{ mW} \times 10 = 1000\text{ mW}$
 - ▶ $1000\text{ mW} \times 10 = 10000\text{ mW}$
 - ▶ $10000\text{ mW} \times 2 = 20000\text{ mW} = 20\text{ W}$

dB math

- ▶ exercise:
 - ▶ express -26 dBm in Watts
 - ▶ $-26\text{dB} = -10\text{dB} - 10\text{dB} - 3\text{dB} - 3\text{dB}$
 - ▶ $1\text{ mW} / 10 = 100\text{ }\mu\text{W}$
 - ▶ $100\text{ }\mu\text{W} / 10 = 10\text{ }\mu\text{W}$
 - ▶ $10\text{ }\mu\text{W} / 2 = 5\text{ }\mu\text{W}$
 - ▶ $5\text{ }\mu\text{W} / 2 = 2.5\text{ }\mu\text{W}$

dB math

- ▶ when quantifying the gain of an antenna, the decibel units are usually represented by **dB*i***
- ▶ the *i* stands for isotropic, which means that the change in power is referenced against an isotropic radiator
- ▶ an **isotropic radiator** is a theoretical ideal transmitter that produces an e.m. field in all directions with equal intensity at a 100% efficiency
- ▶ other decibels units are also used, as for example the **dB*d*** which is a measure of the gain of an antenna system relative to a dipole antenna

antenna gain

- ▶ an antenna element is a passive device
- ▶ the antenna can create the effect of amplification by virtue of its physical shape

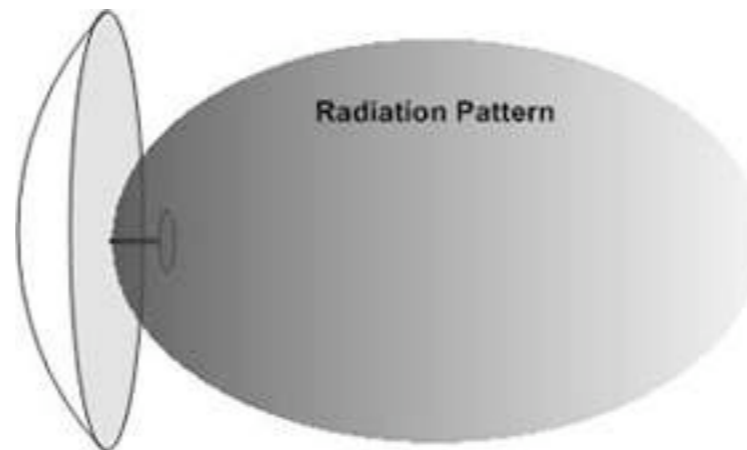

- ▶ by **intentional radiator** we mean the RF device and all cabling and connectors up to, but not including, the antenna

intentional radiator

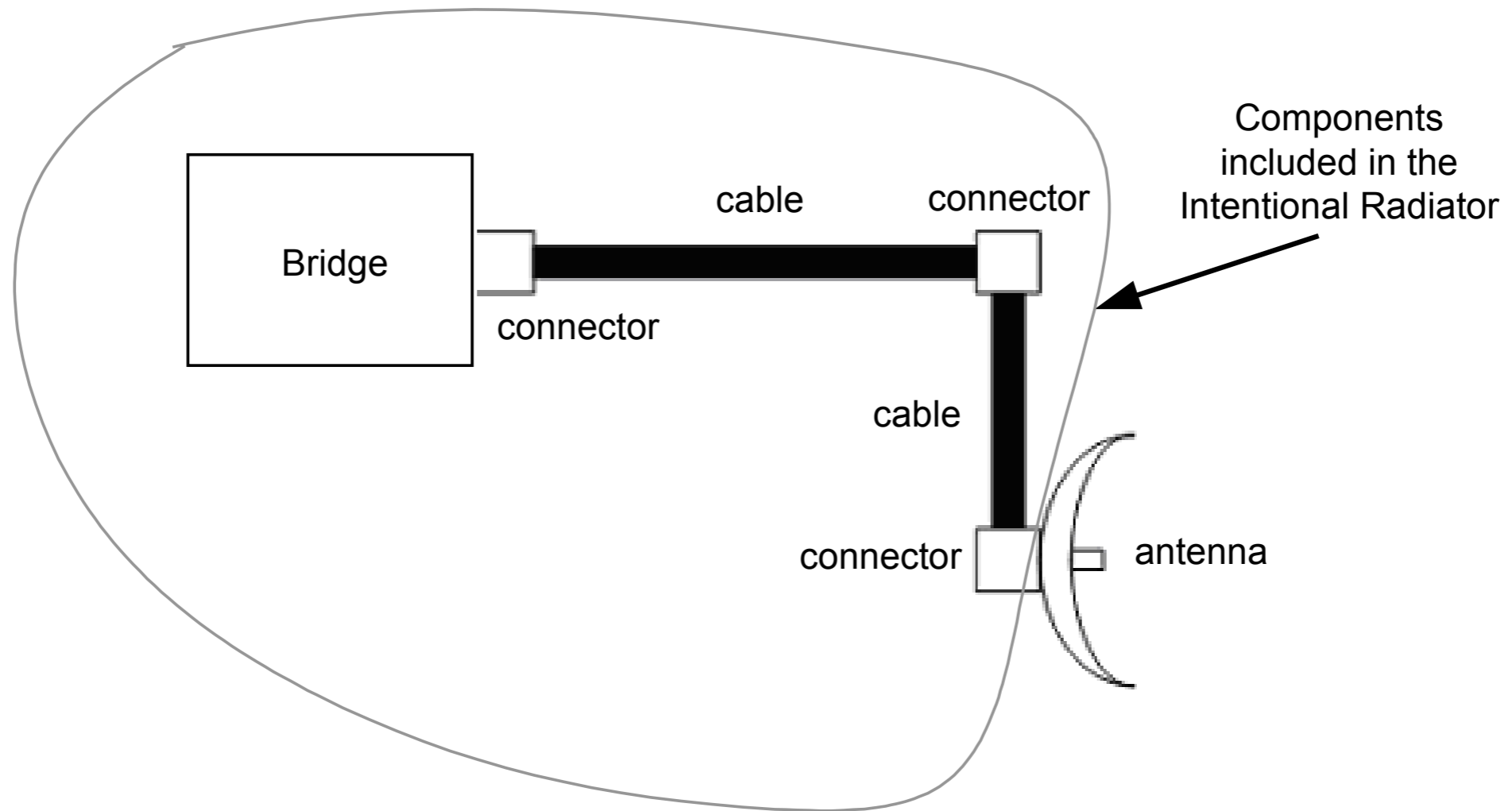

intentional radiator

- ▶ any reference to “**power output of the Intentional Radiator**” refers to the power output at the end of the last cable or connector before the antenna
- ▶ for example:
 - ▶ if a 30 mW transmitter loses 15 mW of power in the cables and another 5 mW in the connectors, the power of the intentional radiator is 10 mW

intentional radiator

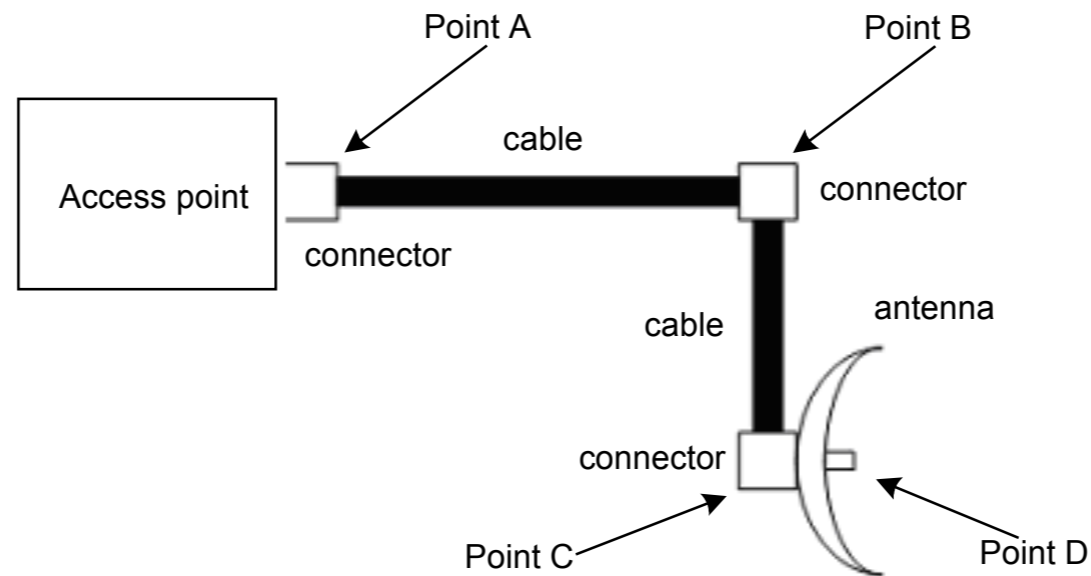

<u>Access Point</u>	<u>Point A</u>	<u>Point B</u>	<u>Point C</u>	<u>Point D</u>
100 mW	-3 dB	-3 dB	-3 dB	+12 dBi
= 100 mW	÷2	÷2	÷2	(x2 x2 x2 x2)
= 100 mW	÷2	÷2	÷2	x16
= 50 mW		÷2	÷2	x16
= 25 mW			÷2	x16
= 12.5 mW				x16
= 200 mW				

EIRP

- ▶ the EIRP is the **Equivalent Isotropically Radiated Power**
- ▶ EIRP is the power actually radiated by the antenna element and is important because
 - ▶ it is regulated by the FCC or other regulatory agency
 - ▶ it is used in calculating whether or not a wireless link is viable

EIRP

- ▶ the EIRP takes into account the gain of the antenna

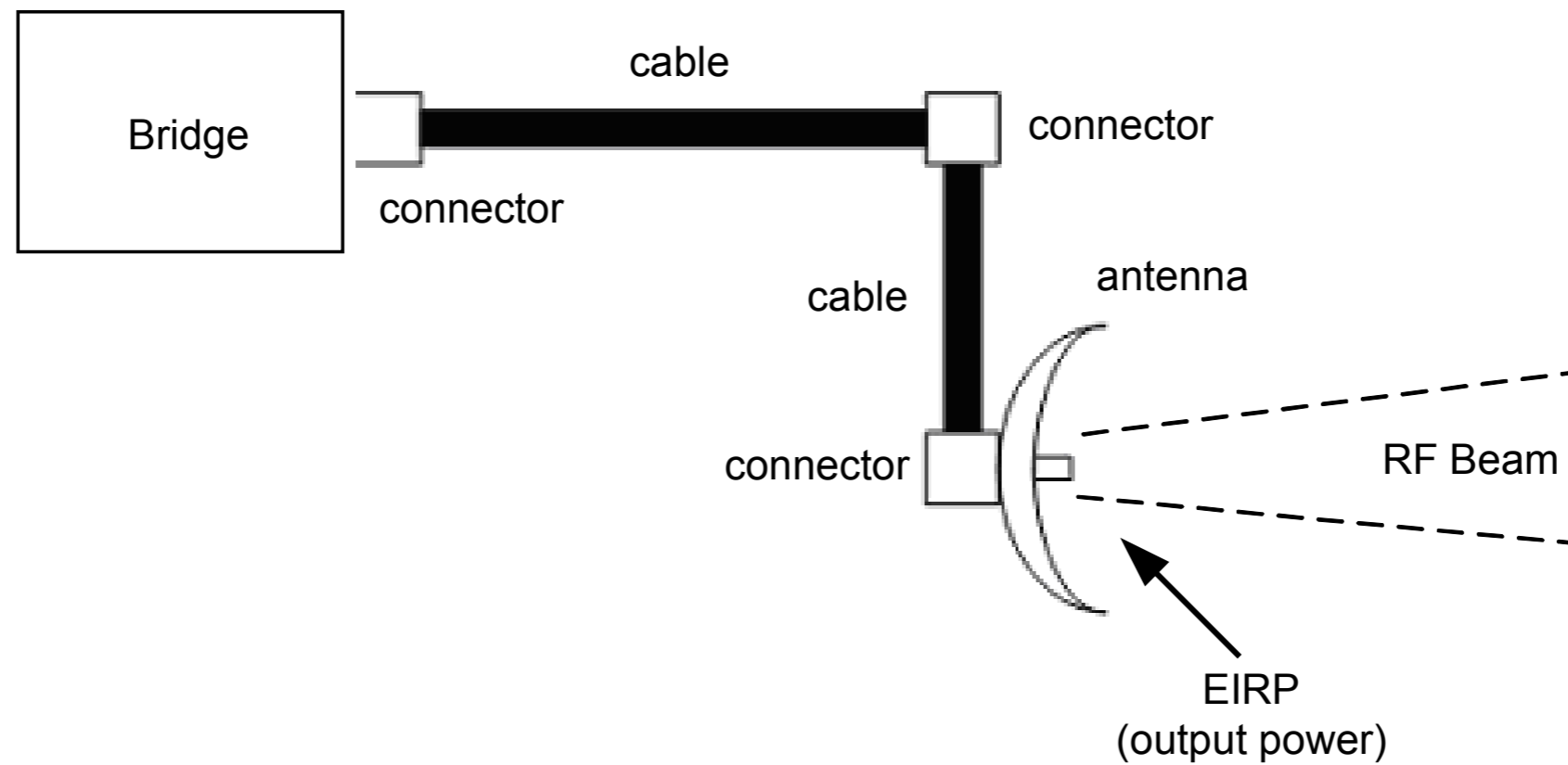

EIRP

- ▶ suppose a transmitting station uses a 10 dBi antenna (which amplifies the signal 10 times) and is fed by 100 mW from the intentional radiator
- ▶ the EIRP is 1000 mW or 1 W
- ▶ the FCC has rules defining both the power output at the intentional radiator and the antenna element

EIRP

- ▶ the FCC enforces certain rules regarding the power radiated by the antenna element, depending on whether the implementation is point-to-multipoint (PtMP) or point-to-point (PtP)
- ▶ PtMP links are typically configured in a star topology
- ▶ when an omnidirectional antenna is used, the FCC automatically considers the link a PtMP link

PtMP

- ▶ in the setup of a point-to-multipoint link, the FCC limits the EIRP to 4 Watts
- ▶ the power limit set for the intentional radiator is 1 Watt
- ▶ is the transmitting LAN devices are adjustable with respect to their output power, then the system can be customized to the needs of the user

PtMP

- ▶ for example:
 - ▶ a radio transmitting at 1 Watt(+30 dBm) is connected directly to a 12 dBi omnidirectional antenna
 - ▶ the total output power at the antenna is about 16 Watts, which is well above the 4 Watts limit
 - ▶ the FCC stipulates that for each 3dBi above the antenna's initial 6dBi of gain, the power of the intentional radiator must be reduced by 3dB below the initial +30dBm

PtMP

- ▶ for our example, since the antenna gain is 12dBi, the power of the intentional radiator must be reduced by 6dB
- ▶ this reduction will result in an intentional radiator power of 24 dBm, or 36 dM of EIRP which is 4 Watts
- ▶ the end result is that the power at the intentional radiator must never be more than 1 Watt, and the EIRP must never be above 4 Watts for a PtMP connection

P_tM_P

Power at Antenna (dBm)	Antenna Gain (dBi)	EIRP (dBm)	EIRP (watts)
30	6	36	4
27	9	36	4
24	12	36	4
21	15	36	4
18	18	36	4
15	21	36	4
12	24	36	4

PtP

- ▶ point-to-point links include a single directional transmitting antenna and a single directional receiving antenna
- ▶ the FCC mandates that for every 3 dBi above the initial 6 dBi of antenna gain, the power at the intentional radiator must be reduced by 1 dB from the initial +30 dBm
- ▶ consider the previous example: 1 W (+30 dBm) at the intentional radiator and a 12 dBi antenna (directional antenna in this case)

PtP

- ▶ the total output power is still 16 Watts
- ▶ since the antenna gain is 12 dBi, the power at the intentional radiator must be reduced by 2 dB
- ▶ this reduction will result in an intentional radiator power of 28 dBm (30-2), and an EIRP of 40 dBm or 10 Watts
- ▶ in the case of PtP links, the power of the intentional radiator is still limited to 1 Watt, but the limit of the EIRP increases with the gain of the antenna

PtP

Power at Antenna (dBm)	Max Antenna Gain (dBi)	EIRP (dBm)	EIRP (watts)
30	6	36	4
29	9	38	6.3
28	12	40	10
27	15	42	16
26	18	44	25
25	21	46	39.8
24	24	48	63
23	27	50	100
22	30	52	158

Fresnel zone

- ▶ the **Fresnel Zone** occupies a series of concentric ellipsoid-shaped areas around the Line-of-Sight path
 - ▶ RF LOS is different that visual LOS
 - ▶ visual LOS is present when one can stand next one antenna and use binoculars to view the other antenna
 - ▶ RF LOS requires not only a visual sight line between the antennas but it also requires that a football shaped area between the two antennas be free of obstructions

Fresnel zone

- ▶ the fresnel zone is an area that is larger in diameter at the center and smaller in diameter at either end. Also, the greater the distance between the antennas, the larger the diameter of the fresnel zone in the center.
- ▶ the Fresnel Zone is important to the integrity of the RF link because it defines an area around the LOS that can introduce RF signal interference if blocked
- ▶ objects in the Fresnel Zone as trees, hilltops and buildings can diffract or reflect the main signal away from the receiver

Fresnel zone

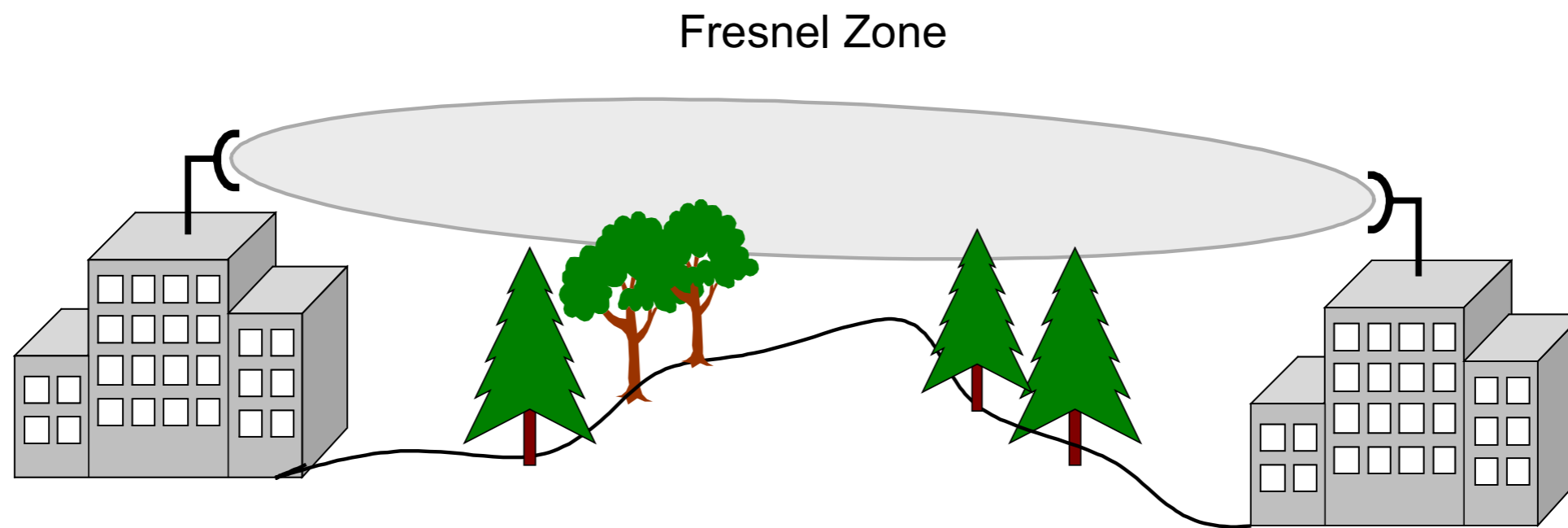

Fresnel zone

- ▶ the radius of the Fresnel Zone at its widest point can be calculated as
 - ▶ $r = 43.3 \times \sqrt{d/4f}$
 - ▶ where d is the link distance in miles, f is the frequency in GHz and the answer r is in feet
 - ▶ $r = 17.3 \times \sqrt{d/4f}$
 - ▶ where d is the link distance in kilometers, f is the frequency in GHz and the answer r is in meters
- ▶ at 2.4 GHz, for a distance of 10 km, the Fresnel Zone has a radius of 17.6 meters

Fresnel zone

- ▶ considering the importance of the Fresnel Zone, it is important to quantify the degree to which it can be blocked
- ▶ typically, 20% to 40% Fresnel Zone blockage introduces little to no interference into the link
- ▶ it is better to err to the conservative side, allowing no more than 20% blockage of the Fresnel Zone
- ▶ <http://gbppr.dyndns.org:8080/fresnel.main.cgi>

Propagation Basics

- ▶ signal power is diminished by geometric spreading of the wavefront, commonly known as **Free Space Loss**
- ▶ signal power is **attenuated** as the wave passes through solid objects as trees, walls, windows and floors of buildings
- ▶ the signal is **scattered** and can interfere if there are objects in the beam of the transmit antenna even if these objects are not in the direct path between the transmitter and the receiver

Free Space Loss

- ▶ geometric spreading happens because the wavefront radiated signal's energy expands as a function of the distance from the transmitter
- ▶ using decibels to express the loss and using 2.45 GHz as the signal frequency, the equation for the **Free Space Loss** is
 - ▶ $L_{\text{fsl}} = 40 + 20 \cdot \log(r)$
 - ▶ where L_{fsl} is expressed in dB and r in meters

Attenuation

- ▶ when the RF signal passes through solid objects, some of the signal power is absorbed
- ▶ the most convenient way to express this is by adding an **“allowed loss”** to the Free Space
- ▶ attenuation can vary greatly depending upon the structure of the object the signal is passing through
- ▶ metal in the barrier greatly increases the attenuation

Attenuation

- ▶ trees account to 10 to 20 dB of loss per tree in the direct path. Loss depends upon the size and the type of tree
- ▶ walls account to 10 to 15 dB depending upon the construction
- ▶ floors of buildings account 12 to 27 dB of loss. Floors with concrete and steel are at the high end and wood floors at the low end
- ▶ mirrored walls have very high loss because the reflective coating is conductive

Scattering

- ▶ RF signals can reflect off of many things and the direct signal combines with signals that have reflected off of objects that are not in the direct path
- ▶ this effect is usually described as **multipath**, fading or signal dispersion

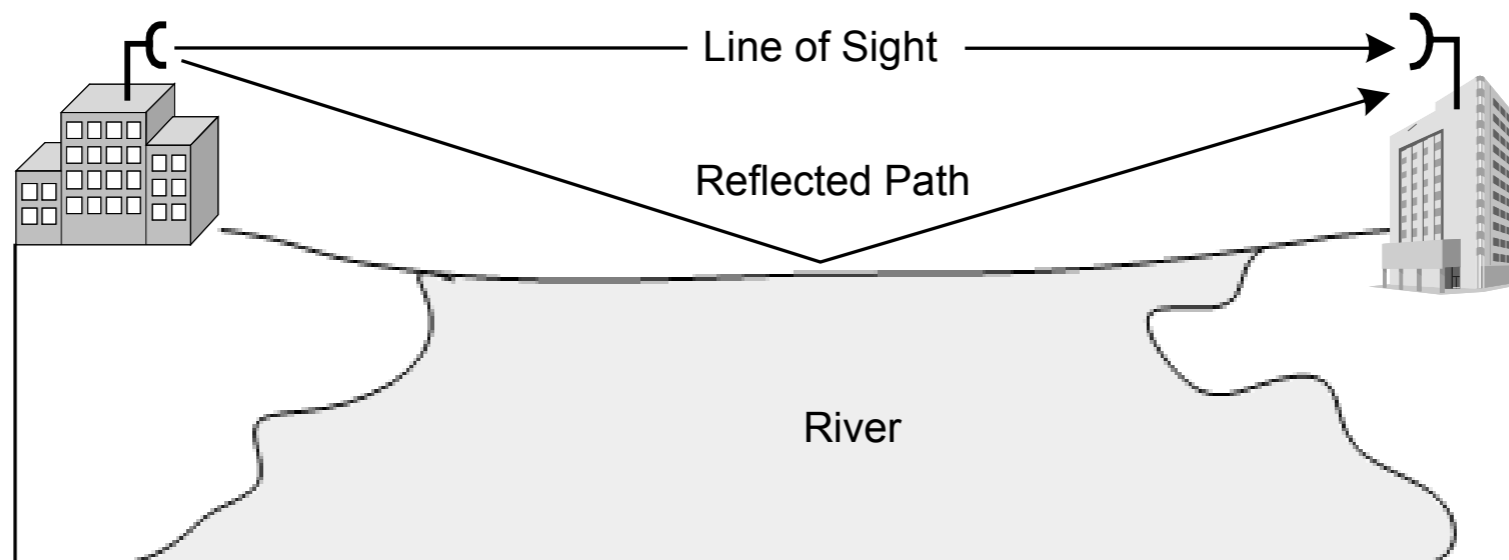

Scattering

- ▶ the distortion degrades the ability of the receiver to recover the signal in a manner much like signal loss
- ▶ multipath can cause several different conditions, all of which can affect the transmission of the RF signal differently

Decreased Signal Amplitude

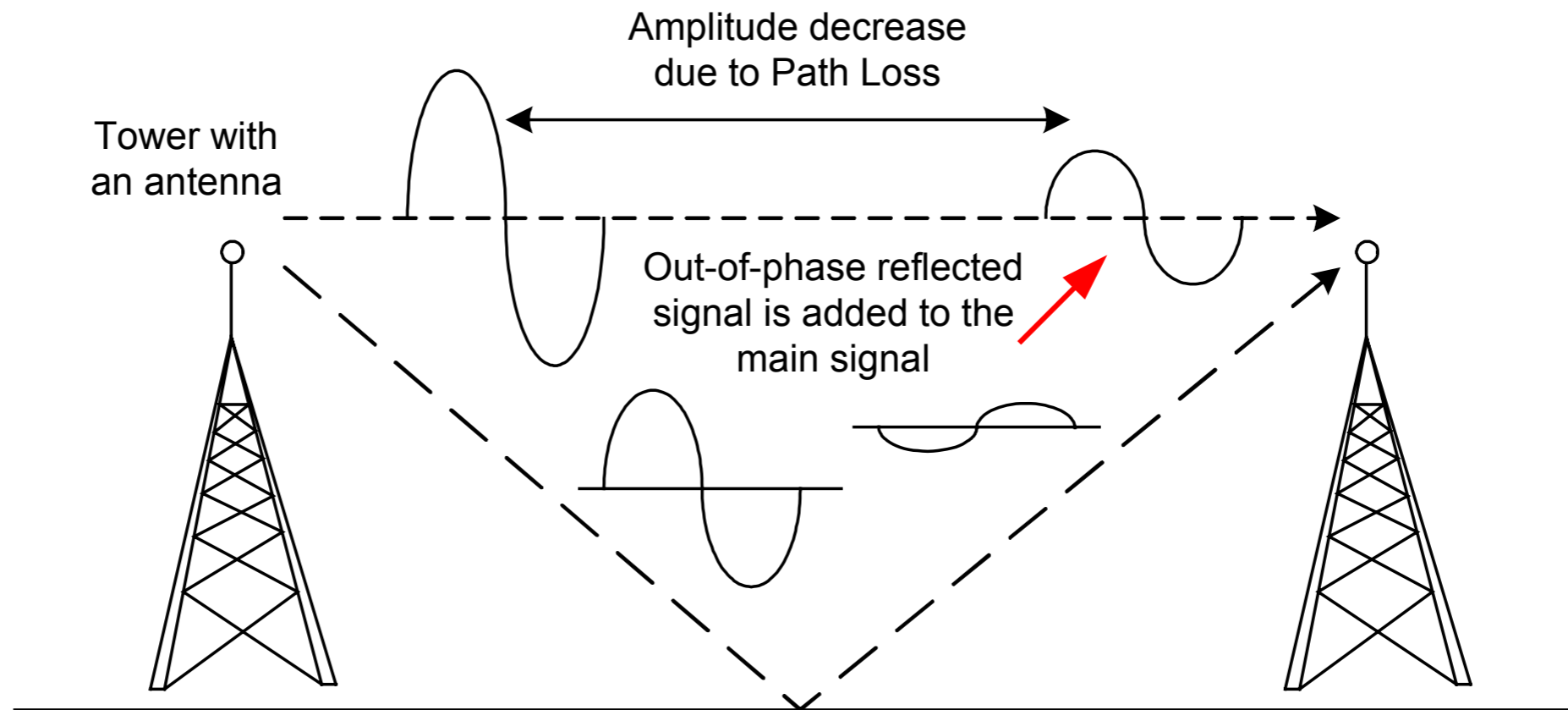

Corruption

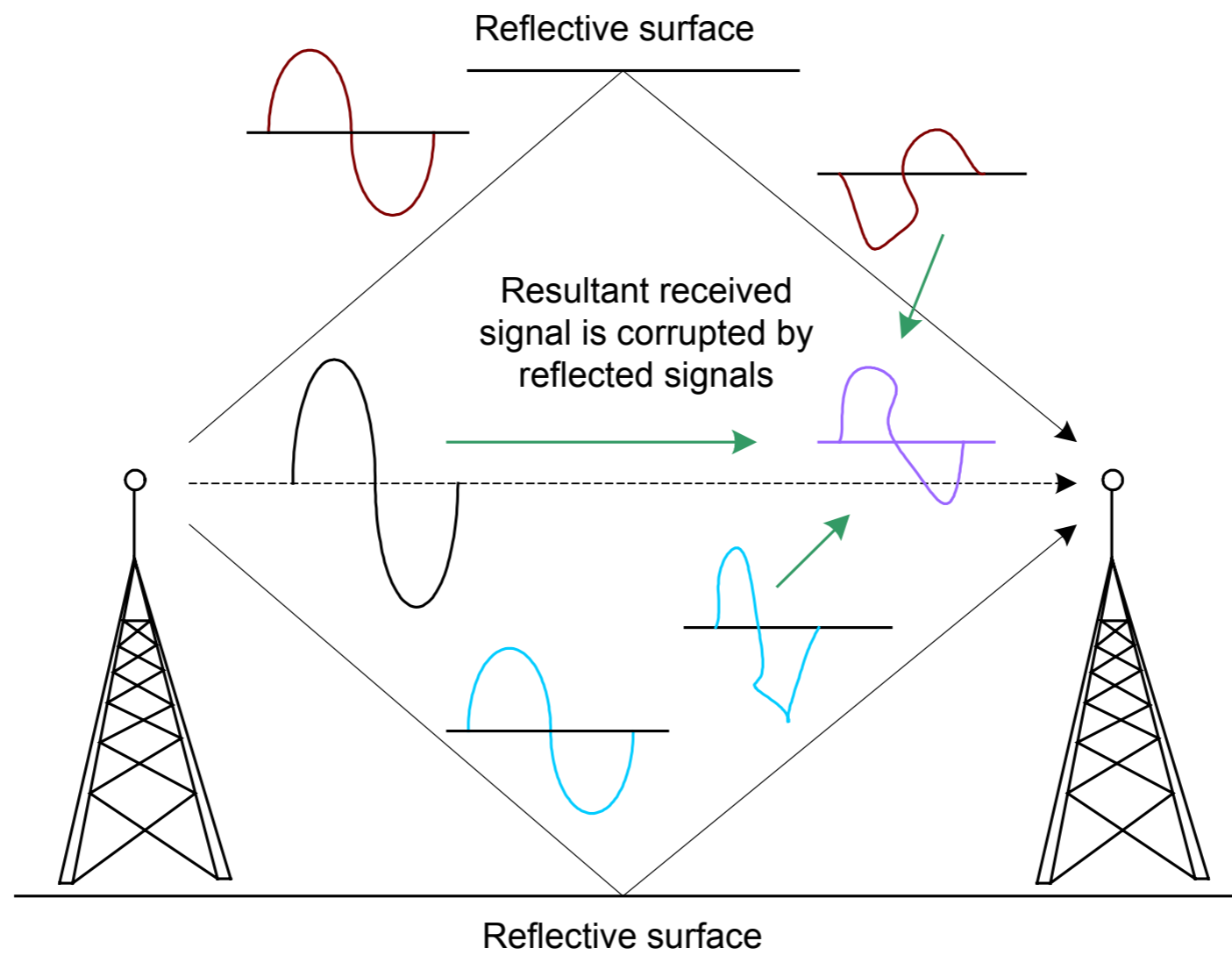

Nulling

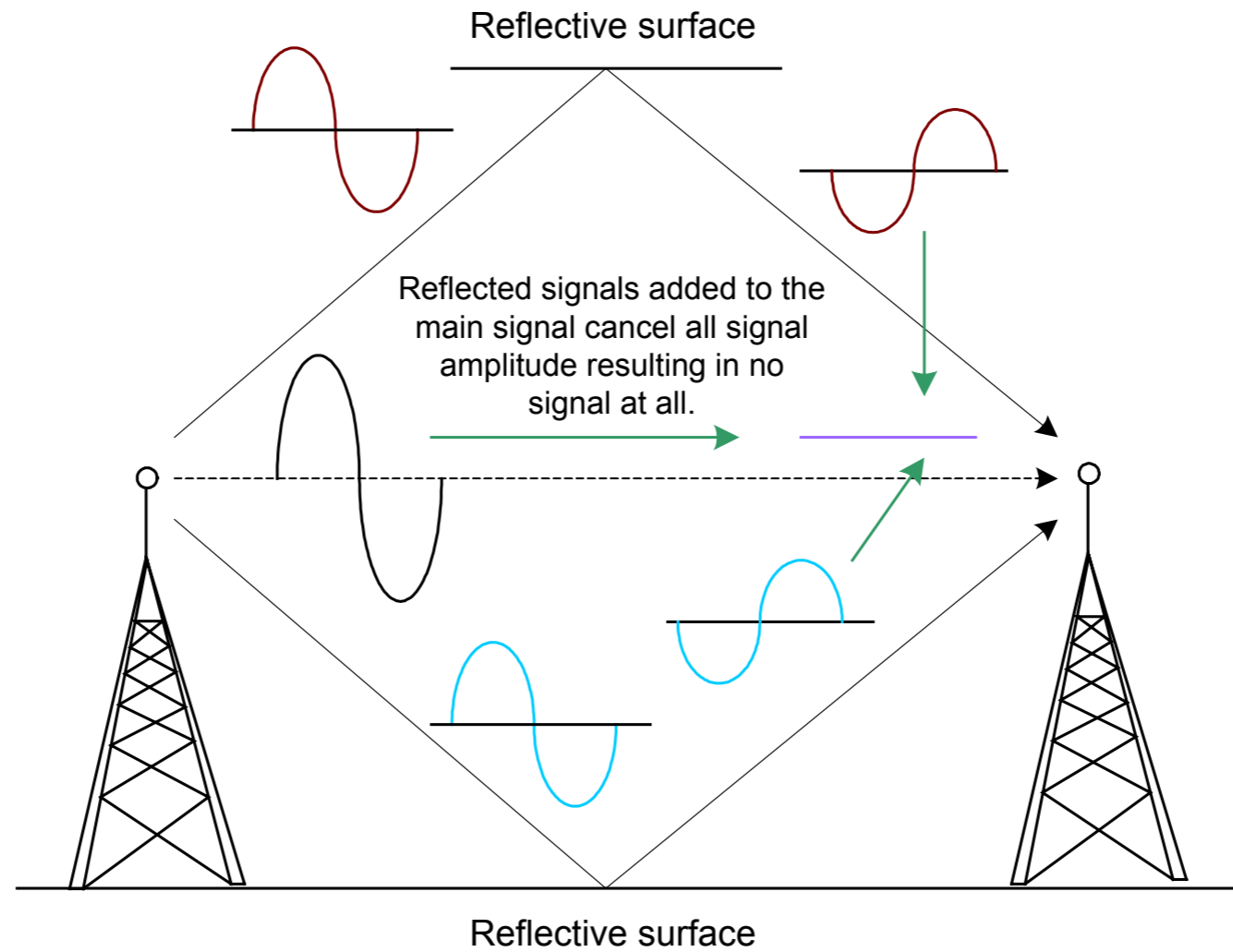

Increased Signal Amplitude

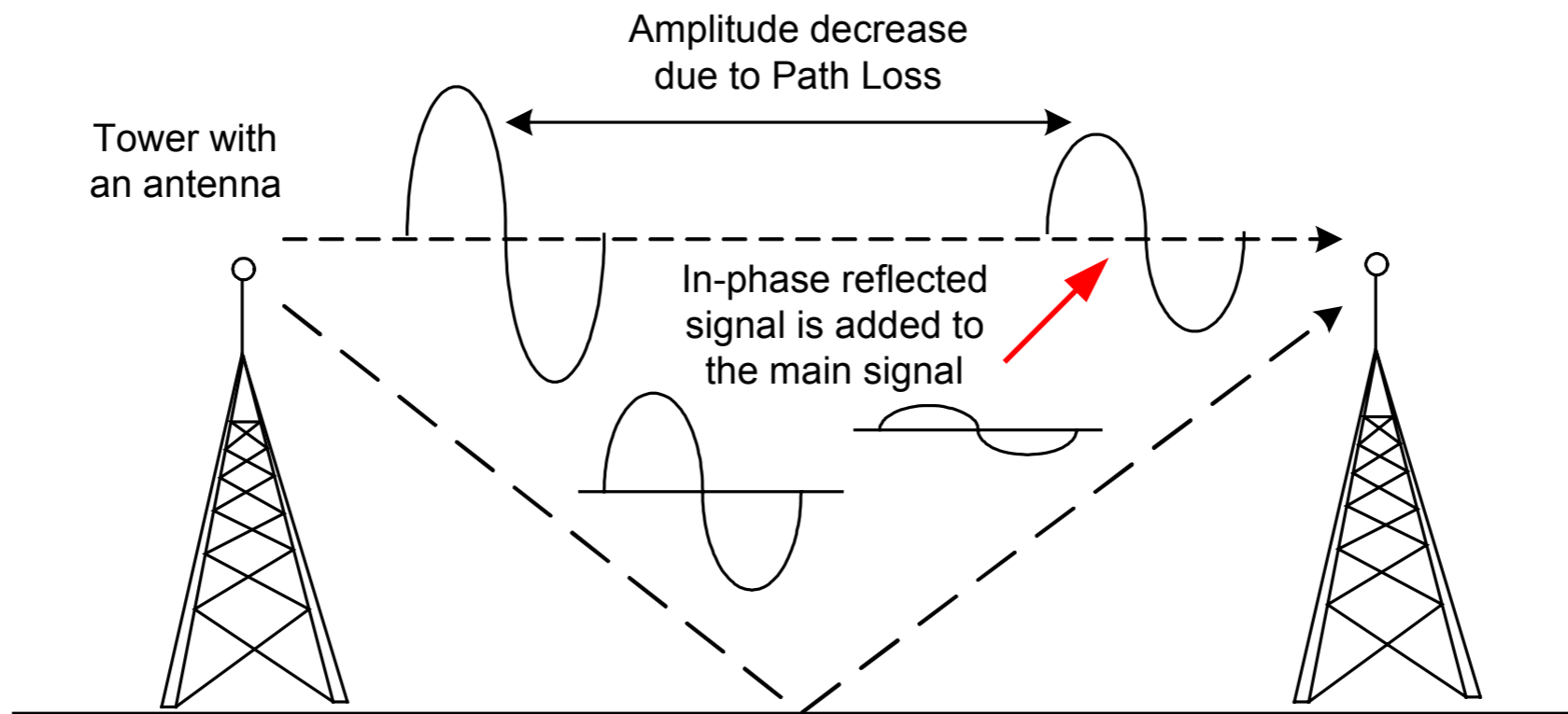

Scattering

- ▶ **antenna diversity** was devised for the purpose of compensating the multipath
- ▶ antenna diversity means using multiple antennas in order to compensate the conditions that cause multipath
- ▶ antenna switching diversity: multiple antennas on multiple inputs, with a single receiver. The signal is received through only one antenna at a time
- ▶ transmission diversity: transmits out of the antenna last used for reception. Can alternate antennas for retries

Scattering

- ▶ a simple way of applying the effects of scattering is to **change the exponent** on the distance factor of the Free Space Loss formula like this:
 - ▶ $L(\text{dB}) = 40 + 10 * n * \log(r)$
- ▶ the exponent tends to increase with the range in an environment with a lot of scattering
- ▶ calculating a range can often require some iteration of the exponent to be used

Total Loss

- ▶ when Free Space Loss, Attenuator and Scattering are combined, the loss is

$$L(\text{dB}) = 40 + 10 * n * \log(r) + L_{\text{allowed}}$$

Link Margin

- ▶ the performance of any communication link depends on the quality of the equipment being used
- ▶ the **link margin** is a way of quantifying equipment performance
- ▶ an 802.11 link has an available link margin that is determined by **four factors**

Link Margin

- ▶ Transmit Power
- ▶ Transmit Antenna Gain
- ▶ Receive Antenna Gain
- ▶ Cable Losses, Connector Losses and Lightning Arrestor Losses
- ▶ Minimum Received Signal Strength or Level
- ▶ the link margin is then

$$\text{TX(power)} + \text{TX(ant gain)} + \text{RX(ant gain)} - \text{RSL}$$

Link Margin

- ▶ the link factors are usually listed in the manufacturer's data sheets for the equipment being used
- ▶ note that the minimum **RSL is dependent upon rate** and the 1 Mbps rate is used for maximum range
- ▶ TX power can also be rate dependent but manufacturers rarely indicate this

Maximum Range

- ▶ **the maximum range is achieved when the signal loss is less than the link margin**
 - ▶ we must know the equipment parameters and must estimate the allowed loss and the scattering exponent to complete the calculation
 - ▶ the equipment parameters can be found on the data sheets
 - ▶ <http://www.qsl.net/n9zia/>

Maximum Range

Application	Allowed Loss (dB)	Scattering Exponent	Example
Outdoor free space	0	2	
Outdoor, no barriers	0	2.5 at 200m 3 at 400m 3.5 > 500m	Marina
Outdoor with trees	10 to 20	3 to 4	Park
Outdoor buildings	0	4	Urban café
Indoor - no barriers	0	2.5	Conference room
Indoor partitions	0	3.5	Office cubicles
Indoor walls & floors	12 to 27 (floors) 10 to 15 (walls)	4 to 5	Condo, apartment

Power over distance

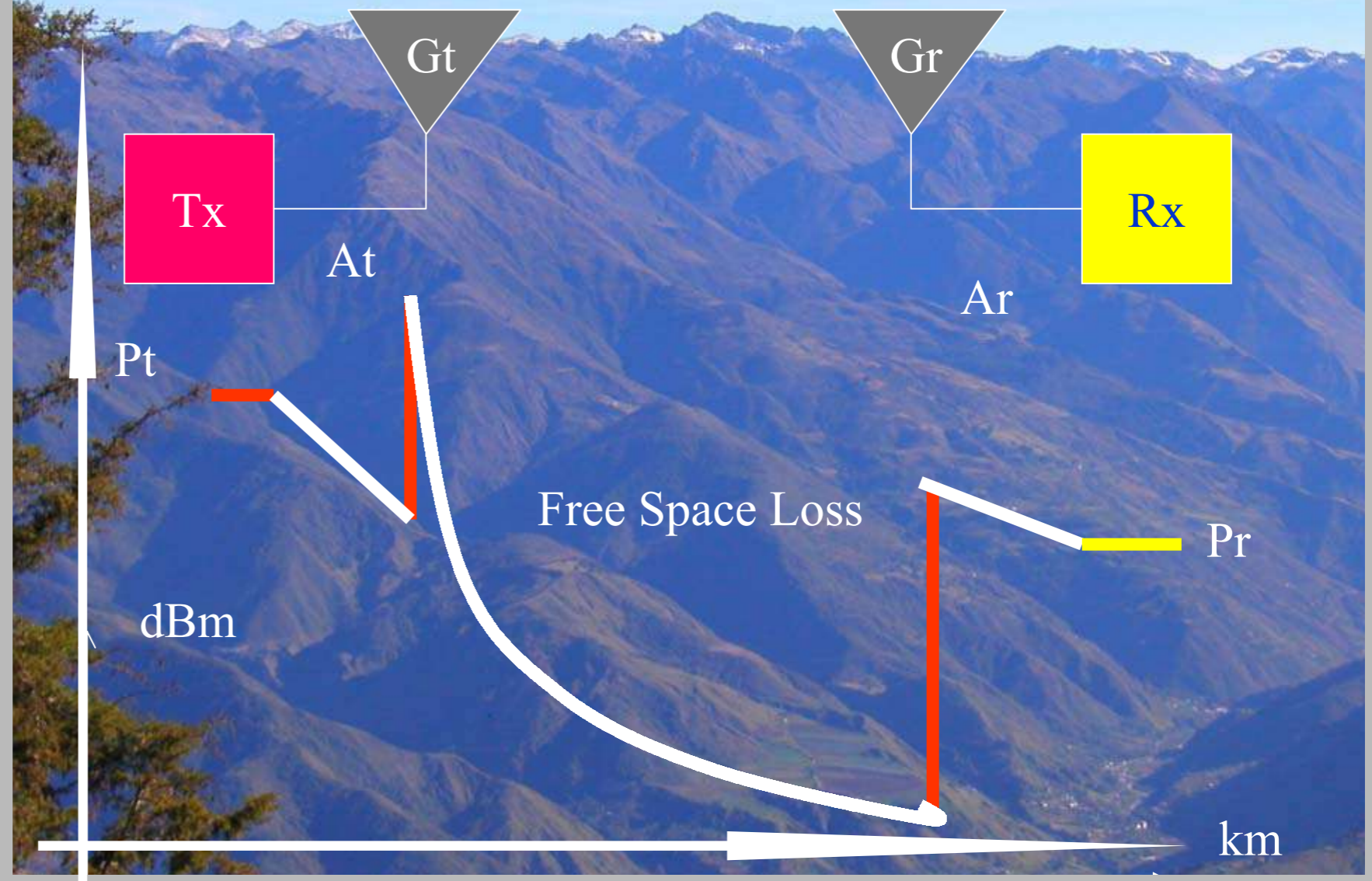

Link Margin

Example

- ▶ suppose a university wants to setup a point-to-multipoint link



Example

- ▶ Access Point:
 - ▶ TX Power: 13 dBm
 - ▶ TX Antenna Gain: 8.5 dBi
- ▶ PC Cards:
 - ▶ RX Antenna Gain: 0 dBi
 - ▶ RX Sensitivity: -89 dBm

Example

- ▶ the link margin is
 - ▶ $\text{TX}(\text{power}) + \text{TX}(\text{ant gain}) + \text{RX}(\text{ant gain}) - \text{RSL}$
 - ▶ $13 + 8.5 + 0 - (-89) = 110.5 \text{ dB}$

Example

- ▶ we can estimate the allowed loss to be 10 dB if the park had a modest number of trees mixed with open spaces and use a scattering exponent of 3

- ▶ to get the maximum range we solve

$$110.5 = 40 + 10 * 3 * \log(r_{\max}) + 10$$

and we find

$$r_{\max} = 102 \text{ meters}$$

Example

- ▶ using the same equation to calculate the range assuming free space loss only (exponent=2, and allowed loss=0)

$$110.5 = 40 + 10 * 2 * \log(r_{\max}) + 0$$

$$r_{\max} = 3264 \text{ meters}$$

- ▶ this example shows that **environmental factors can play a significant role in diminishing the signal strength**

Link Budget Calculation

Thank you for your attention!

► Contact info:

Marco Zennaro

mzennaro@ictp.it

<http://wireless.ictp.it>