

Wireless equipment selection



Sebastian Büttrich
<http://wire.less.dk>

sebastian@wire.less.dk



Agenda

Scope

Criteria for choosing hardware

Features

Types of Wifi hardware

Anatomy of an AP/Router

Some products ...

Note: we put focus not on specific products and discussions like “is A better than B” - we rather try to discuss criteria and strategies for planning and purchasing.

Scope

Wireless is a strange definition, because it defines what it is NOT: it is NOT bound to wires.

In that sense, optical transmission, FM radio, bluetooth, ... are all wireless. Even smoke signs are.

Here, we will focus on **802.11 a,b and g** and mention some closely related technologies.

The term **Wifi** was used for 802.11b only in the beginning, but today applies to the **802.11 a,b and g** substandards.

Certifying and owning the Trademark: The Wifi Alliance, <http://www.wi-fi.org/>

| standard | frequency | gross data rate | modulation |
|-----------------|------------------|------------------------|-------------------|
| 802.11a | 5.2 GHz | 54 Mbps | OFDM |
| 802.11b | 2.4 GHz | 11 Mbps | DSSS |
| 802.11g | 2.4 GHz | 54 Mbps | OFDM, PBCC |

Criteria

How to choose standards and products

- ▶ As always: **your requirements** are key – what do you wanna do?
- ▶ **Budget & availability**
 - ▶ especially for wireless gear: consider price development!
Do not buy or budget for 500 today, what next year might cost 100.
- ▶ **Legal considerations:**
what is legally & *practically* :) possible where you are?
- ▶ Where applicable: **support/drivers** for your Operating system?
- ▶ **Environmental specifications:** temperature! humidity! dust! snow! :)
- ▶ **Power consumption**

Criteria

How to choose standards and products

▶ **Support situation:**

a medium quality device with good support will work better than a top quality device without support ... agree?
Support can be through external or internal skills!

▶ **Social / human factors:**

sometimes acceptance is based on non-technological factors

▶ **Standards vs. proprietary solutions:**

in a fast developing world, it is more important to be based on standards, than to have the latest *supa dupa speedo booster*TM
Avoid technology lock-in!
Allow for incremental development and change!

▶ **Ask others for experience!** Via Google, newsgroups, wikis, mail lists, ...

Criteria: 802.11 a/b/g?

How to choose the right standard – what are a, b and g good for?

- 802.11b oldest, robust, good for indoors and outdoors, cheapest
- 802.11g same frequency as 802.11b, higher bandwidth, BUT, because of OFDM, a lot less robust for outdoor longhaul links! For this, it is not a good choice!
- 802.11a because of higher frequency, it does not go through obstacles as well. But, it makes for excellent high bandwidth longhaul links, when LOS is given.
Indoors, it often suffers from Line Of Sight problems.

Criteria: 802.11 a/b/g?

Try it!

Today, many cards and devices are multi-standard anyway, so you can try 802.11 a, b, and g with one setup.

It might even be hard to find equipment that only does one standard ...

Criteria / Features

Features worth keeping in mind:

- ▶ Bandwidth (but never trust the glossy paper!)
- ▶ Reach/Coverage
 - ... but never trust the glossy paper! A single device **NEVER** has a reach!!!
 - Maximum distance info (“up to ...”) is worthless!
 - Hard facts like output power and receive sensitivity* say a lot more.
- ▶ Chipset
- ▶ Security features / possibilities (e.g. VPN passthrough, Firewalling, ...)
- ▶ Power over ethernet (PoE, IEEE 802.3af) where applicable
- ▶ Antenna (internal, external, type of connectors?)

Features: output and sensitivity

Examples for output power and receive sensitivity info

Example card:

Receive Sensitivity

- 94dBm at 1 Mbps;
- 88dBm at 2 Mbps;
- 87 dBm at 5.5 Mbps;
- 84dBm at 11 Mbps

Output Power (at the N connector)

- +17.5dBm (max) to
- +11.5dBm (min)

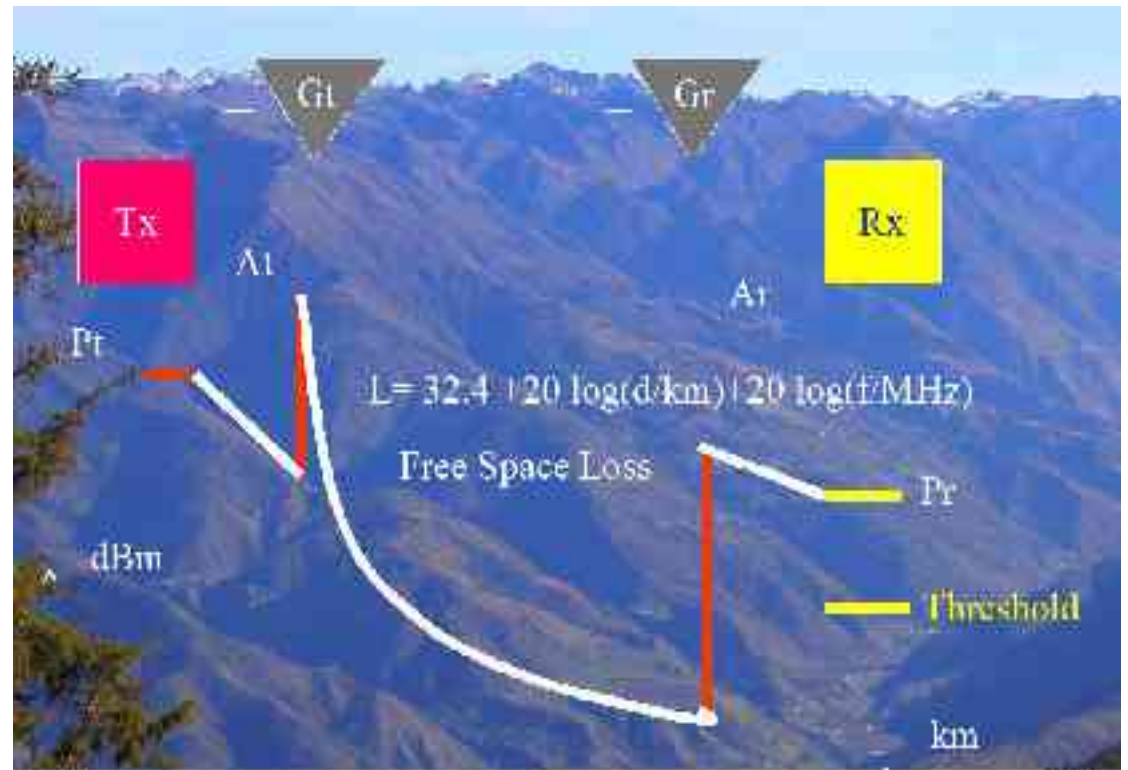

A realistic link budget – to demonstrate how important receiving sensitivity is:

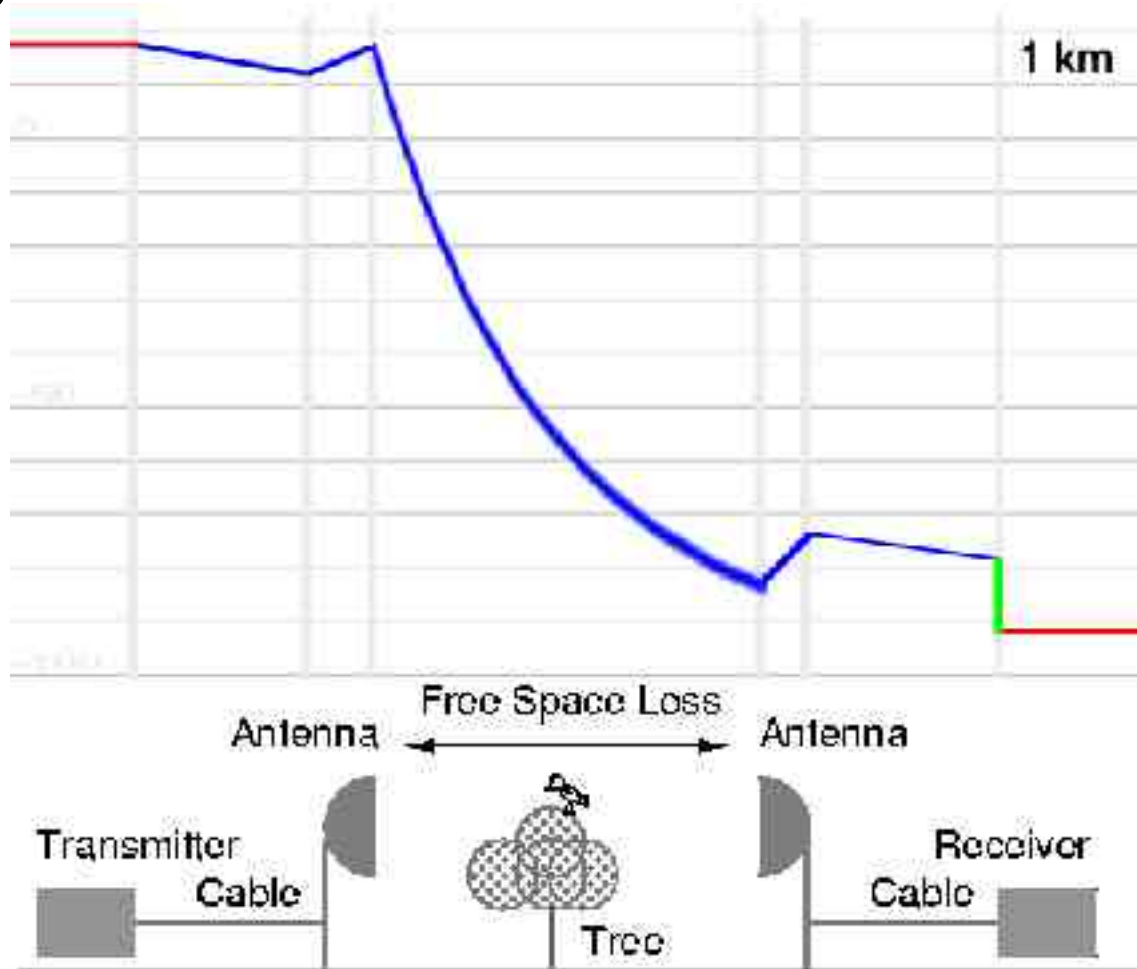

Types of Hardware / Classification

- ▶ Access Point
(includes Access Points, Residential Gateways, DSL & Cable Products)
- ▶ Cellular Convergence
(products that enable both Wi-Fi and cellular communications)
- ▶ Compact Flash
- ▶ Embedded Client
(includes Laptops, Notebooks, mobile phones (future!) etc.)
- ▶ Ethernet Client Device
(includes Wireless-to-Ethernet Station Adapters & Converters)
- ▶ External Card
(includes PC Cards, PCMCIA Cards, CardBus & SD Cards)
- ▶ Internal Card
(includes MiniPCI Cards & PCI Cards)
- ▶ PDAs
- ▶ USB Client Device
(includes Dongles & Adapters)
- ▶ Wireless Printers and Print Servers

Types / Flexibility

This was the list of types as used by the certifier -
however,
the line between types of hardware is not a strict one.

Especially when you build and modify yourself, it makes sense to think of it as
**radio + chipset + surrounding hardware + software
+ all the externals (antennas, power supply, ...)**

Types of usage change over time and may be hard to classify, e.g.
point to point links, bridges, repeaters, mesh nodes (where the line between
client and *AP/server* disappears)

Types: indoor/outdoor

Not a strict line between indoor and outdoor!

Improvising is possible, but do pay attention to environmental specifications ... and how to manage your device if it is on an antenna mast 30 meters high! :) Power over Ethernet is highly recommended here!



One example for interesting low budget outdoors in Egypt <http://www.d128.com/wireless>

Anatomy of an AP/router

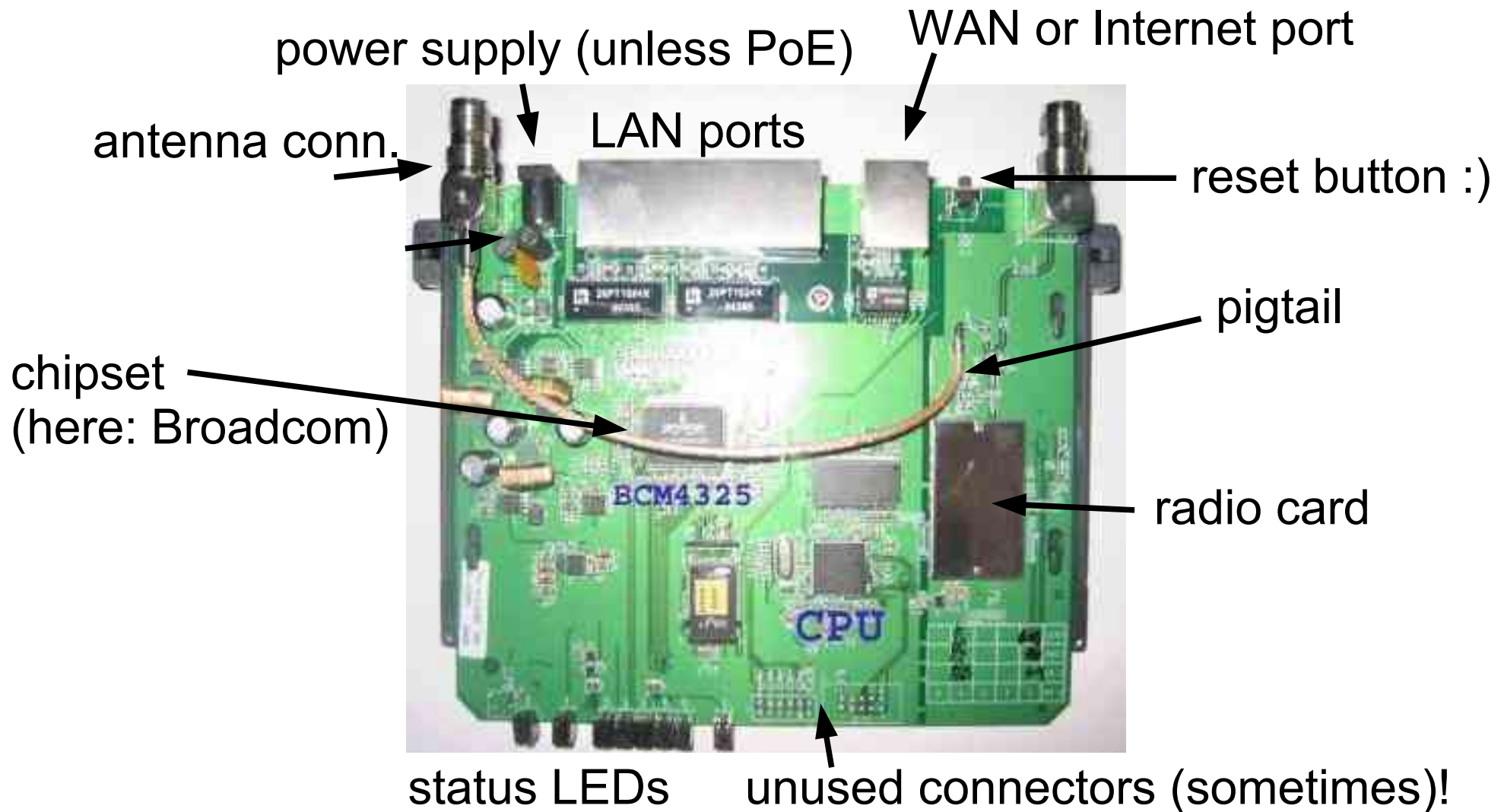

Some Products

The following examples of wireless hardware focus mostly on infrastructure related hardware, i.e. access points, gateways, bridges, point-to-point links rather than pure client cards.

These examples are of course just a personal pick of the author - based on an overview of many international projects.

There are many many more vendors – to name a few we have omitted here: Cisco, 3COM, Gemtek, Tranzeo, Intel, Alvarion/Breezecom, ...

Pricing info in this presentation is meant as a very rough first orientation – prices change fast and are extremely dependent on quantity.

Local availability, pricing and skills easily can be the most important buying points.

Comment: buying strategies

Why buy chinese goods from the US or Germany? :)

If you are in a position to do so,
do not hesitate to establish **new trade routes** -

be that to China, Taiwan, Singapore, India ... or to **local startups!** They exist!

Some Products: PC client cards

Many many vendors.

Older cards for 802.11b, g/b – newer cards are typically a/b/g and based on Atheros chipset.

Sometimes with antenna connectors.

Radio quality (output, sensitivity) varies a lot!

Vendors worth looking at:

Avaya (ex Orinoco)(old b cards!)

Senao (200 mW cards, ext. ant.)

Linksys

D-Link



Some Products: Linksys

- ① Home user equipment that can do many things more, as proven in many projects around the world. Hard to beat in price/performance. Some of their gear runs on GPLed Linux firmware, e.g. the Linksys WRT54G (b+g standards), for which a growing number of firmware hacks exist, including mesh implementations. Comparable vendors in the low price range: e.g. D-Link, Netgear, ...

Good entry points for WRT54G info:

http://www.talug.org/events/20050115/Wireless_Linux/WRT54G_firmware.html

<http://www.seattlewireless.net/index.cgi/LinksysWrt54g>

\$ APs from circa \$50, client cards from \$40, prices falling

www <http://linksys.com>
and lots of independent sites



Some Products: Mikrotik

- ① From Latvia, this company makes 2.4/5 Ghz routers, boards and WISP oriented software.
Very interesting multi-radio (a/b/g) configurations.

\$ from circa \$500 (check list!) for single AP, \$1000 for a link

www <http://www.mikrotik.com>



Some Products: Orinoco/Avaya

① Lucent cards, APs and outdoor routers were among the first widely deployed 802.11b systems and also inside Apple's wireless APs. Name changed to Proxim and then Avaya. Lucent or Avaya Silver and Gold cards (802.11b) are an excellent pick, stable and of high radio quality.

\$ APs from circa \$300, client cards from \$50

www <http://www.avaya.com>

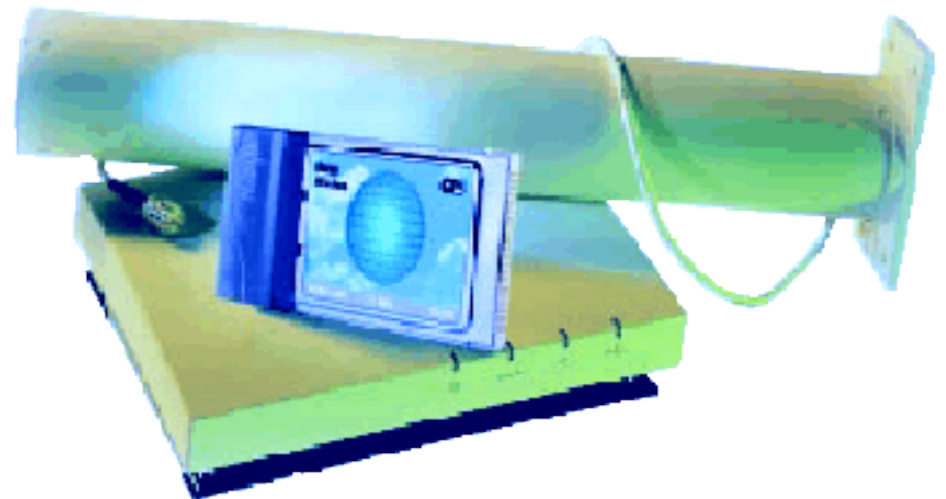

Some Products: Smartbridges

- ① Very good series of point to (multi)point links (airhaul), APs (airpoint), clients. Good global distribution, track record of rural deployments, incl. Mt. Everest. Rated -40 ... +65 celsius!

\$ AP from \$200, Links from < \$400
www <http://www.smartbridges.com>

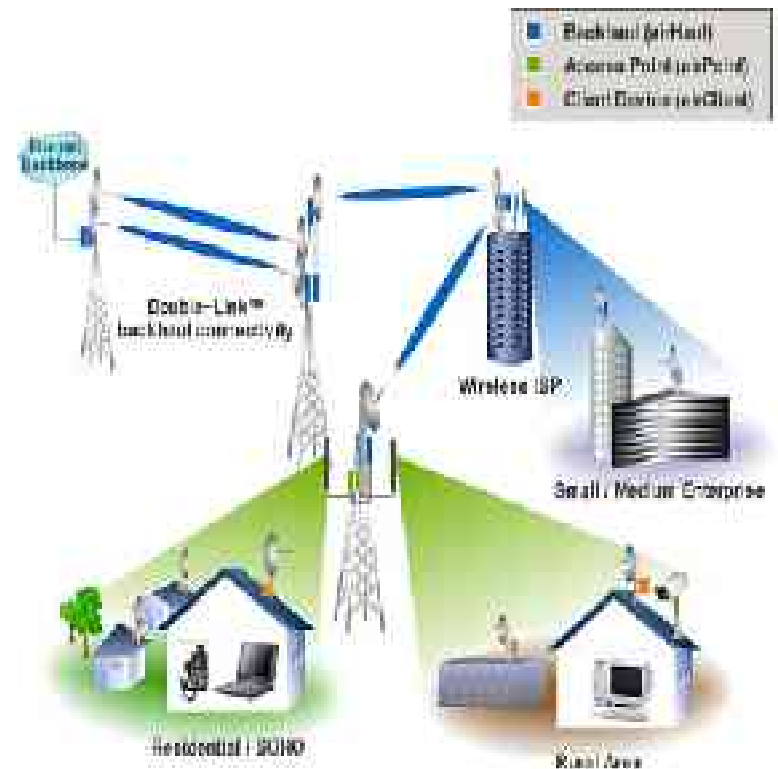

Some Products: Motorola Canopy

- ① Products in (900 MHz), 2.4 GHz and 5 GHz bands. Focus on WISP, carriers, enterprise. Point to point and multipoint links. Proprietary (non-802.11) modulation, very robust.
- \$ From circa \$400-500 per end, \$150 for reflector

www <http://www.motorola.com/canopy/>



Some Products: Redline

- ① Redline Communications systems for both point-to-point and point-to-multipoint deployments.
Backhaul, public access, and private network operator solutions are available for the licensed 3.5 GHz band, and the unlicensed 5.4 GHz and 5.8 GHz bands.

\$ From \$3500-7000 per radio, plus software licenses

www <http://www.redlinecommunications.com/>

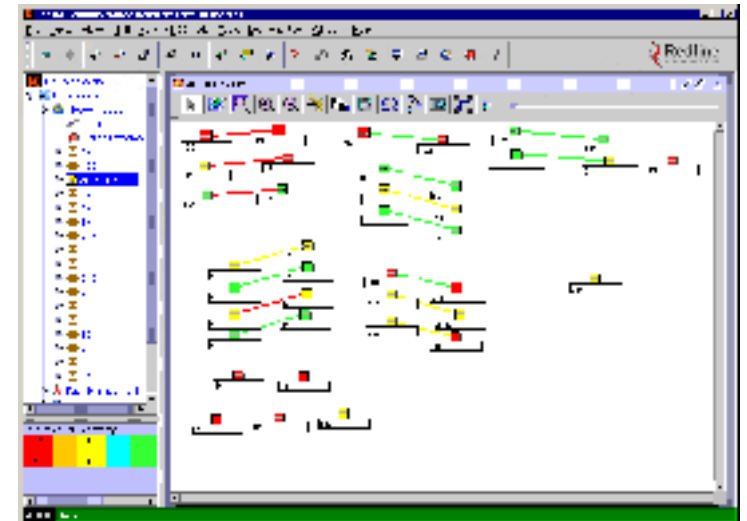

Some Products: 4G Access cube

① The 4G access cube is a little 2-4 radio linux mesh box.

- * dimensions: small (7x5x7cm) cube
- * waterproof outdoor casing
- * no moving parts
- * low power consumption (ca. 4W)
- * power over ethernet (802.3af standard)
- * up to 4 WLAN (802.11a/b/g) interfaces
- * 400MHz MIPS processor AMD Au1500 aka Alchemy
- * 32MB flash
- * 64MB RAM
- * USB host, USB device

\$ from EUR 200 (2 radios)

www <http://meshcube.org>
<http://4g-systems.biz>



Some Products: meshnode

- ① Another little mesh box, made for outdoor use.
Based on WRAP boards.
OLSR mesh routing software.

- # 266 MHz AMD Geode SC1100 CPU 5x86 16Kb cache
- # 64 bzw 128 MB SDRAM
- # 128kb flash
- # RS232
- # 64 MB CF Karte - Grundsystem
- # 2x WISTRON Atheros **a/b/g** Karte
- # Mind. 1 - max. 2 Ethernet Anschlüsse
- # **POE**
- # Busse: LPC bus, ISA style I/O, GPIO, I2C bus
- # Outdoor Gehäuse inkl. N-Anschlüsse
- # LM77 **Thermal-Sensor**

\$ **circa EUR 200, from August 2005**

www <http://meshnode.org>
WRAP boards: <http://www.pcengines.ch/wrap.htm>



Some Products: Soekris boards

① The net4521 board with 2 PC card slots and other Soekris models are popular starting points for building your own wireless hardware - see e.g. the Metrix products.
Great for Linux or BSD.

\$ From circa \$150

www <http://www.soekris.com>

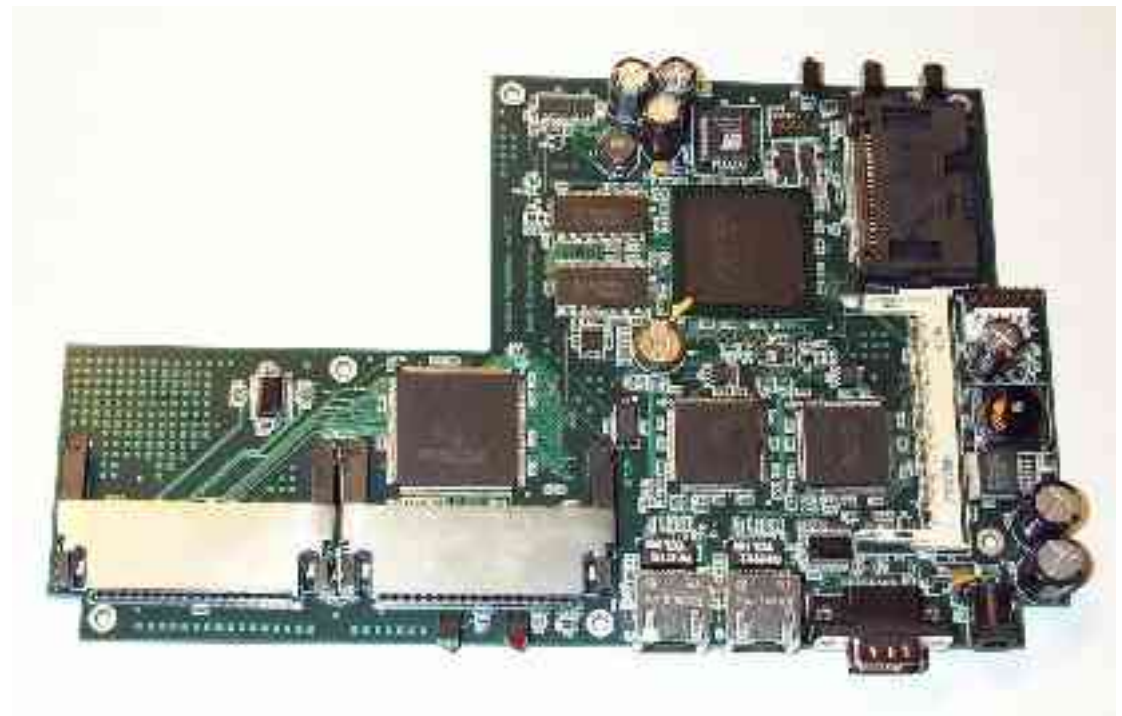

Some Products: Metrix

① Pebble Linux based, multi-purpose, multi-standard boxes

MarkII: “Soekris net4826 motherboard
.... two mini-PCI radio cards”

... can serve as
“Multi-band Access Point,
an Active Repeater,
a Core Infrastructure Node,
an Advanced Wireless Portal,
an Access Point with Rogue AP Detection,
or a Dual Radio Mesh Network Node, ...”

Mark I is the one radio card model,
based on Soekris 4526 board

\$ Mark I: USD 275, Mark II USD 500

www <http://metrix.net>



Some Products: Do it yourself!

- ① Find a piece of old hardware (e.g. a laptop) and one or two radio cards, start with HostAP drivers or the Pebble distro. Parts may also be new. :) Self built wireless components can be of high quality.

\$ From \$0

www <http://www.nycwireless.net/pebble/>
<http://hostap.epitest.fi/>

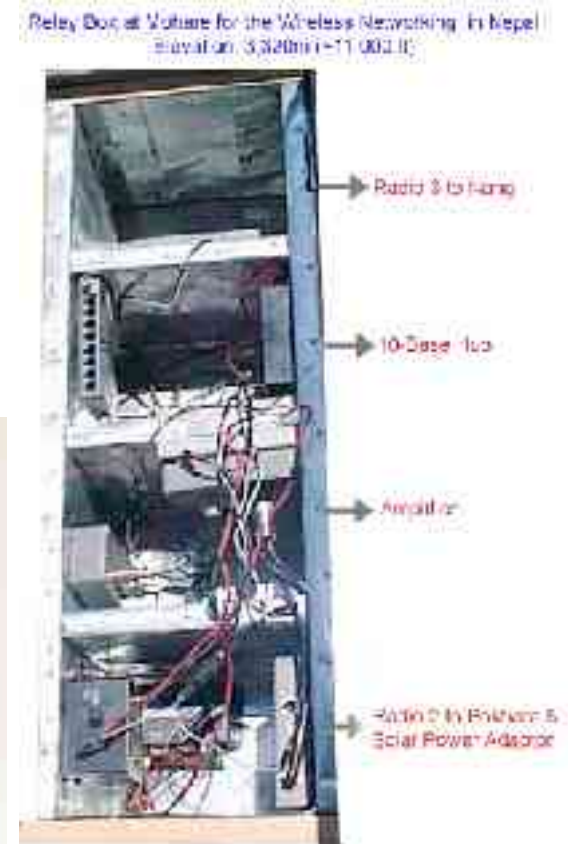

Thanks!

Questions and answers? Comments? Additions?

....

Hands on work in the LAB:

?

sebastian@less.dk

<http://wire.less.dk>

<http://thewirelessroadshow.org>